



MAXLINER

**INSTALLATION
INSTRUCTIONS
MANUAL**

MAXCOVER 180 ABS

FORD RANGER DOUBLE CAB 2022
RAPTOR 2022

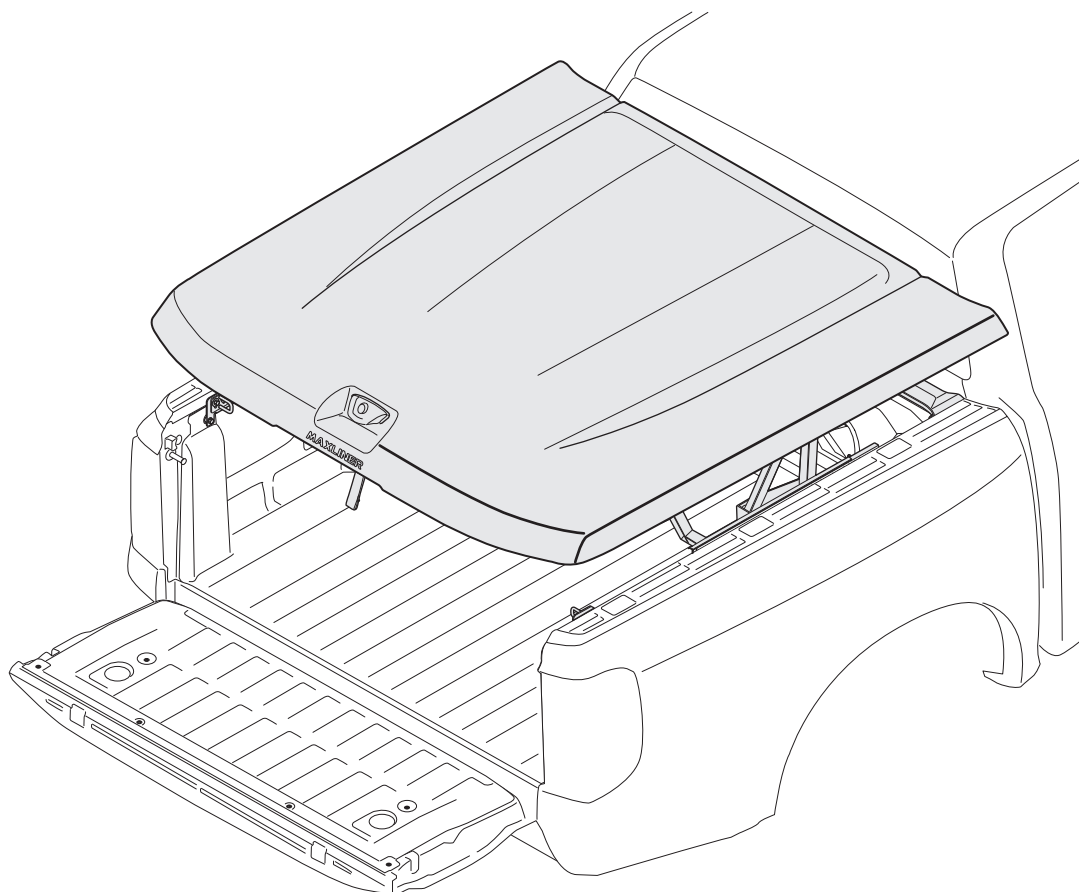

Contact us



THAILAND OFFICE

☎ + (66 38) 468 008 ext 2001
✉ info@maxliner.com
🏠 700/135 Moo 5, Amata Nakorn,
Klongtumru, Muang Chonburi, 20000 Thailand

EUROPE OFFICE

☎ + 31 (0) 850 201 887
✉ infoEurope@vandapac.com
🏠 Aphroditestraat 1 , 5074TW Tilburg , Netherlands
Chamber of Commerce : 71512799
VAT identification number : NL858744272801







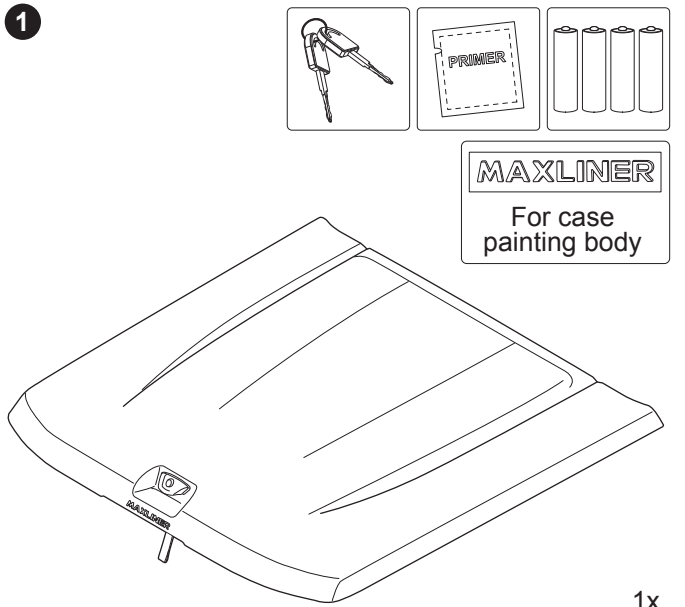
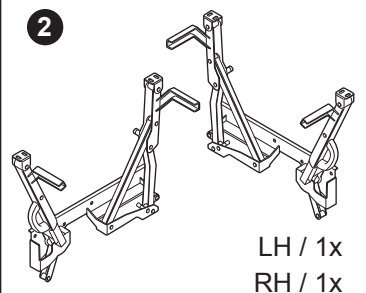
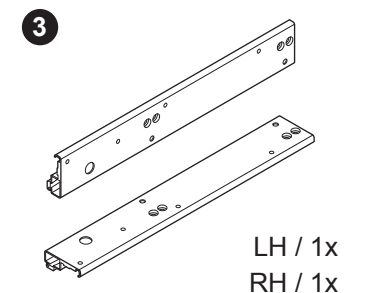
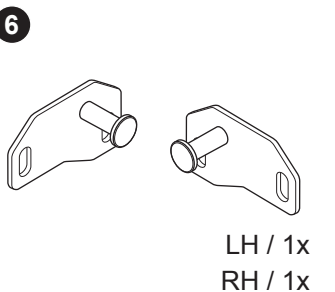
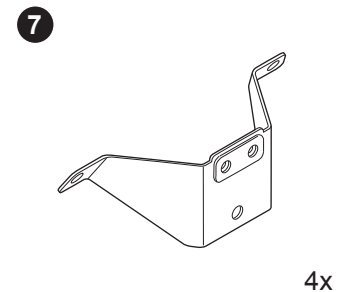
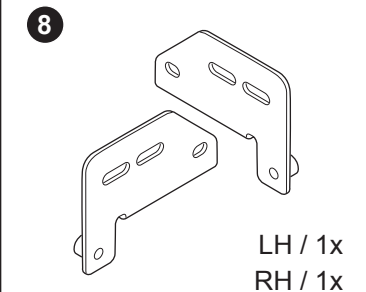
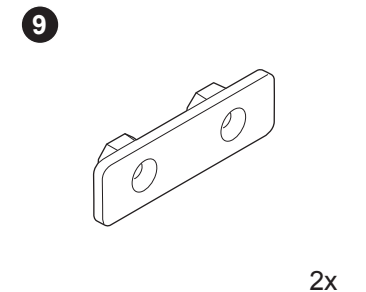
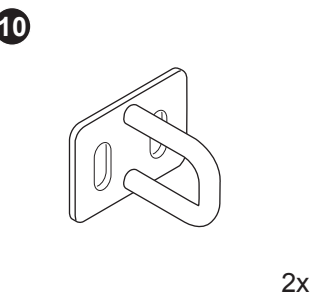
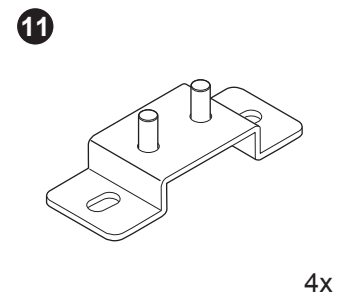
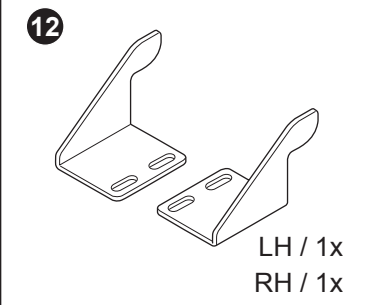
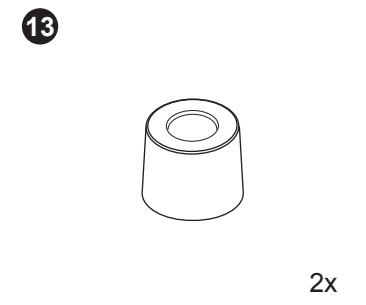
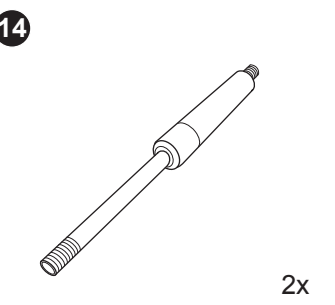
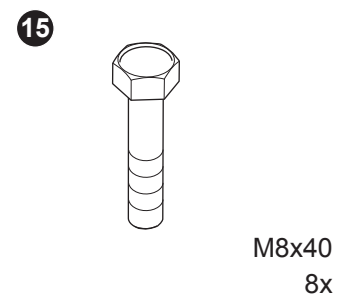
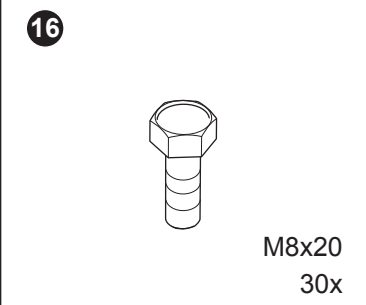
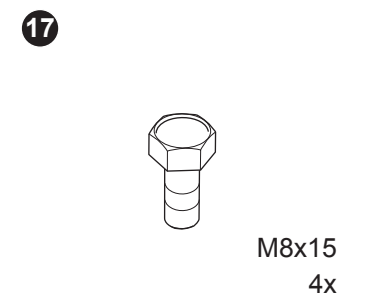
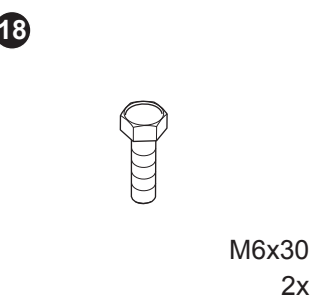
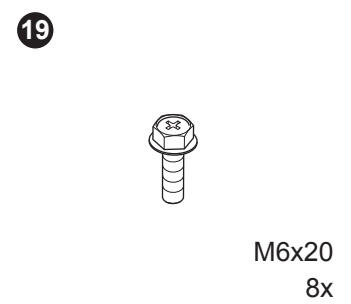
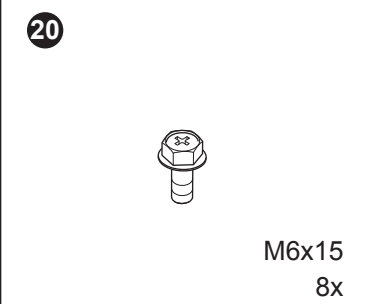
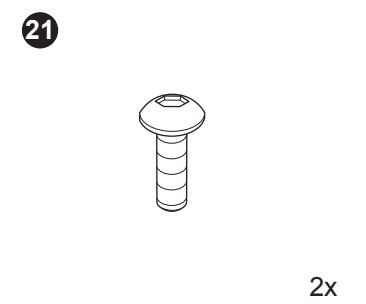

AUSTRALIA/OCEANIA OFFICE

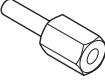
☎ + 61 1800 592 192
✉ sales@maxliner.com.au
🏠 2 Dexter Drive Epping 3076 Australia





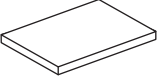
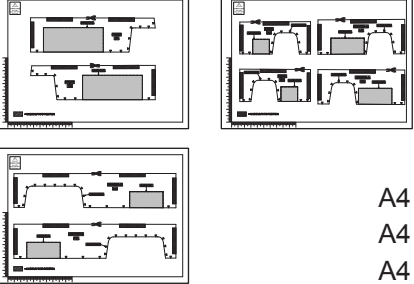
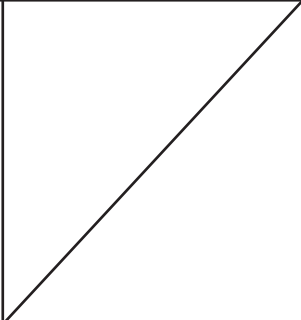
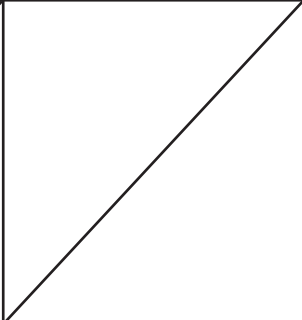
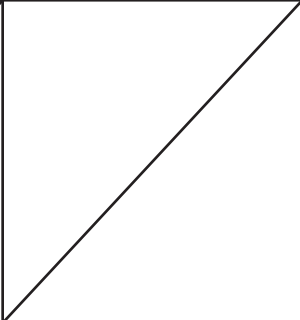

Component parts

<p>1</p>  <p>PRIMER</p> <p>MAXLINER</p> <p>For case painting body</p> <p>1x</p>	<p>2</p>  <p>LH / 1x RH / 1x</p>	<p>3</p>  <p>LH / 1x RH / 1x</p>	
<p>6</p>  <p>LH / 1x RH / 1x</p>	<p>7</p>  <p>4x</p>	<p>8</p>  <p>LH / 1x RH / 1x</p>	<p>9</p>  <p>2x</p>
<p>10</p>  <p>2x</p>	<p>11</p>  <p>4x</p>	<p>12</p>  <p>LH / 1x RH / 1x</p>	<p>13</p>  <p>2x</p>
<p>14</p>  <p>2x</p>	<p>15</p>  <p>M8x40 8x</p>	<p>16</p>  <p>M8x20 30x</p>	<p>17</p>  <p>M8x15 4x</p>
<p>18</p>  <p>M6x30 2x</p>	<p>19</p>  <p>M6x20 8x</p>	<p>20</p>  <p>M6x15 8x</p>	<p>21</p>  <p>2x</p>

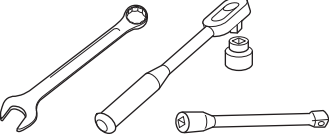
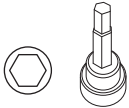
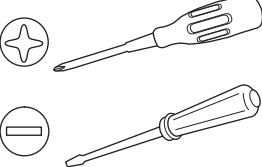
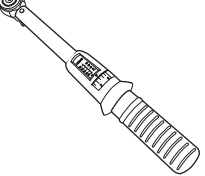
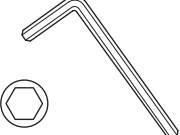
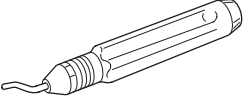
Component parts

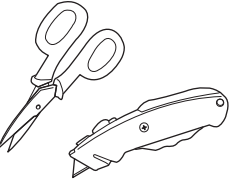
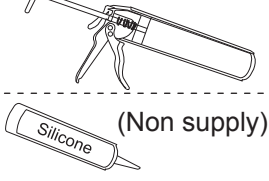
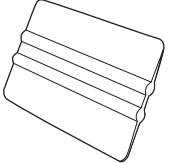
<p>22</p>  <p>M6 8x</p>	<p>23</p>  <p>M8x20 4x</p>	<p>24</p>  <p>M8x25 2x</p>	<p>25</p>  <p>M8 16x</p>	<p>26</p>  <p>2x</p>
<p>27</p>  <p>M8 58x</p>	<p>28</p>  <p>M6 2x</p>	<p>29</p>  <p>M8 58x</p>	<p>30</p>  <p>M6 2x</p>	<p>31</p>  <p>3x</p>
<p>32</p>  <p>A4 / 1x A4 / 1x A4 / 1x</p>				

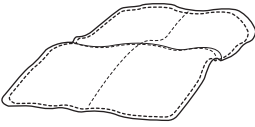
Component parts

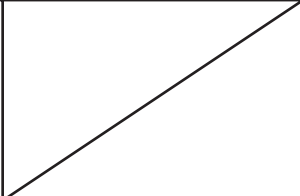
 <p>No.10,12,17</p>	 <p>No.4</p>			 <p>No.2,5,4,5</p>
			 <p>(Non supply)</p>	
				



Caution for installation

Read this mounting manual carefully, before you start the installation.

1. Area where to install product should be clean.
2. During installation, person who installed should take off any ornaments.
3. Wear the protective eyewear before installation.

※ FOR MODEL

With bedliner DC
under rail type
(logo MAX)

With KD liner
(logo MAX)

With bedliner TD type
(logo FORD)

Without bedliner

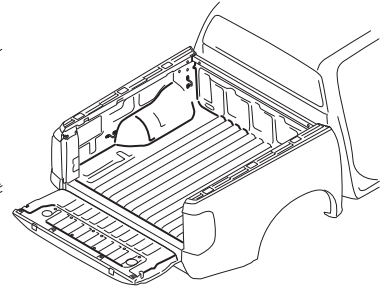
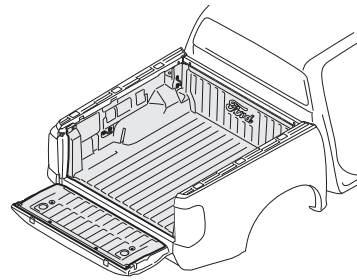
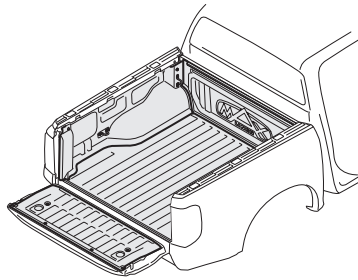
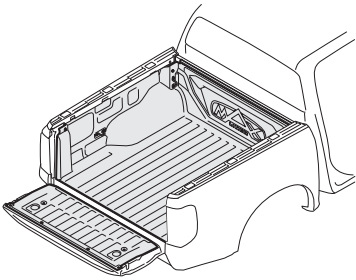

Instruction procedure

1

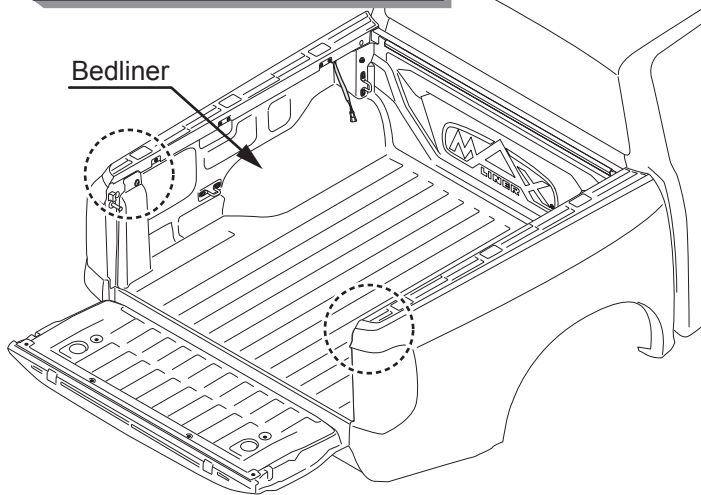
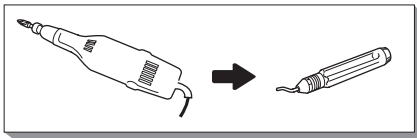

1.1

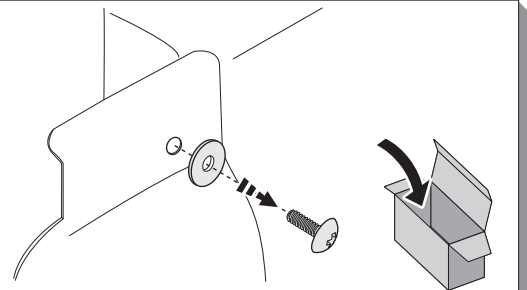

1.2

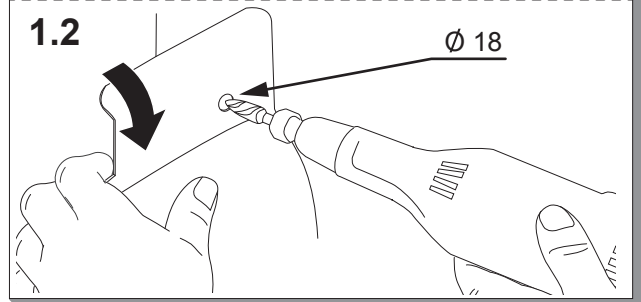

※ For model with bedliner TD type
(logo FORD)

1st

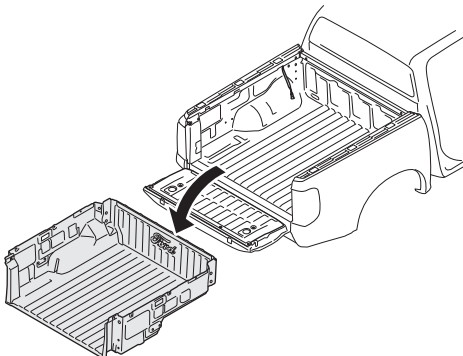

2nd

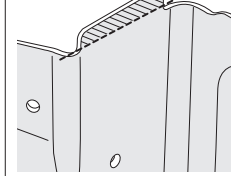

3rd

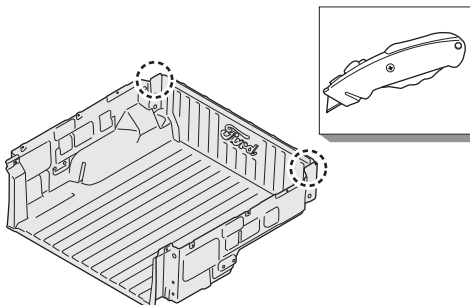
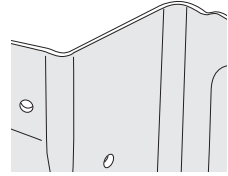

4th

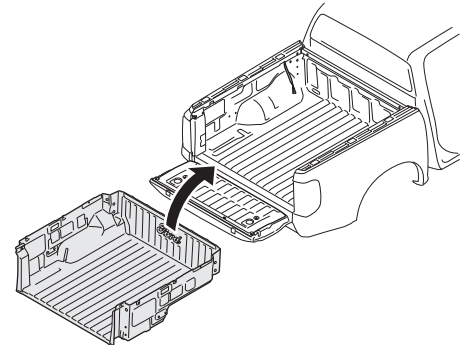

Instruction procedure

2

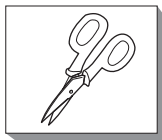

32

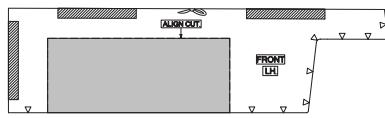
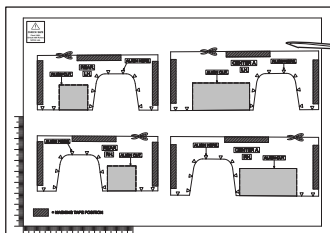
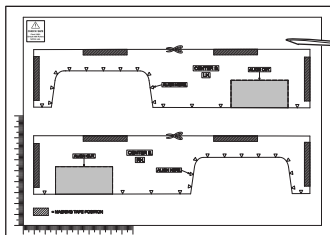
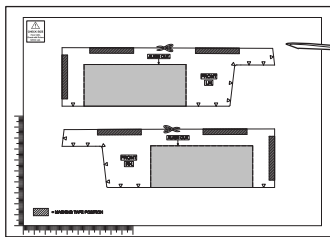

FRONT LH

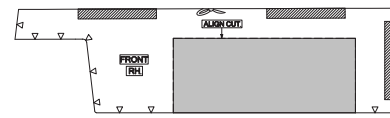

FRONT RH

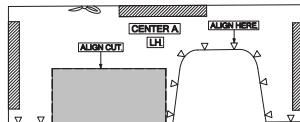

CENTER A LH

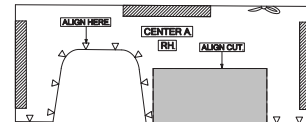

CENTER A RH

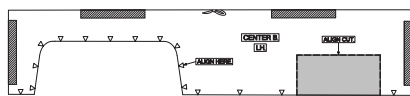

CENTER B LH

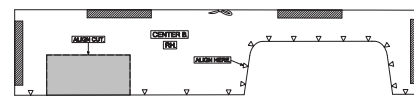

CENTER B RH

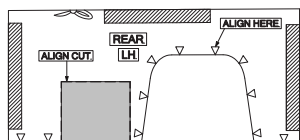

REAR LH

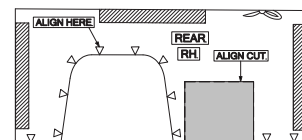

REAR RH

3

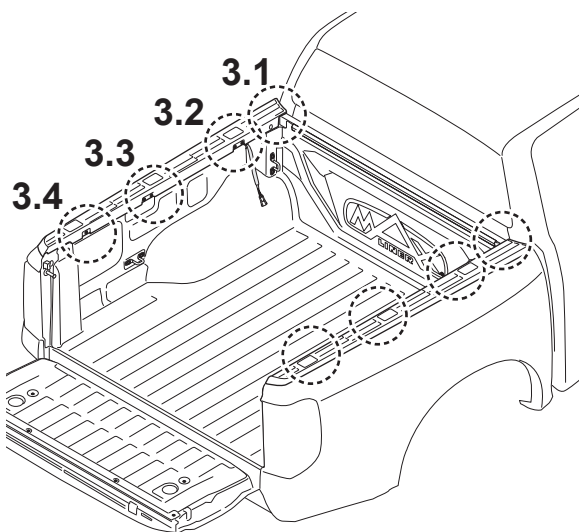
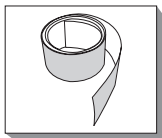

3.1

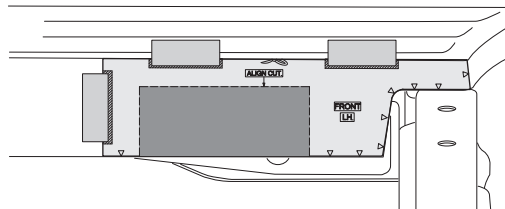

FRONT LH

3.2

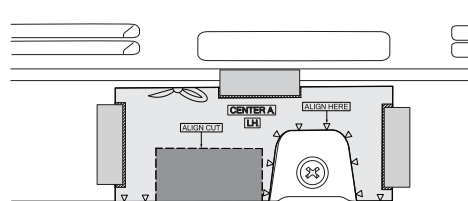

CENTER A LH

3.3

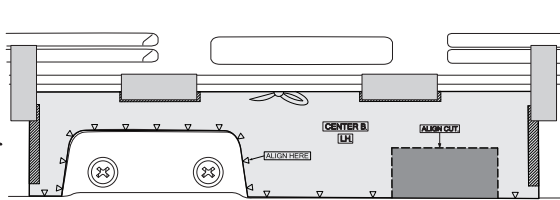

CENTER B LH

3.4

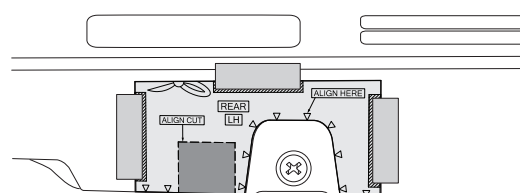

REAR LH

Instruction procedure

4

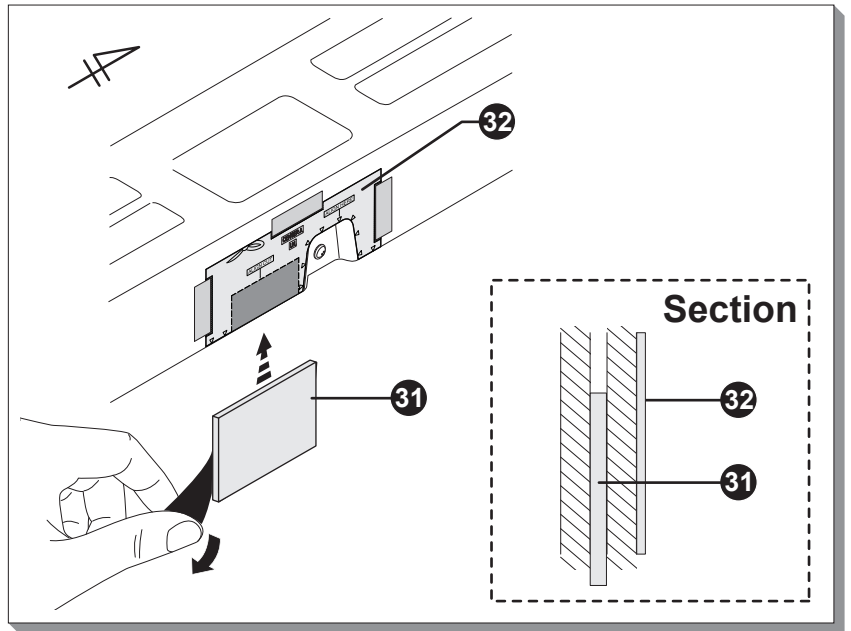
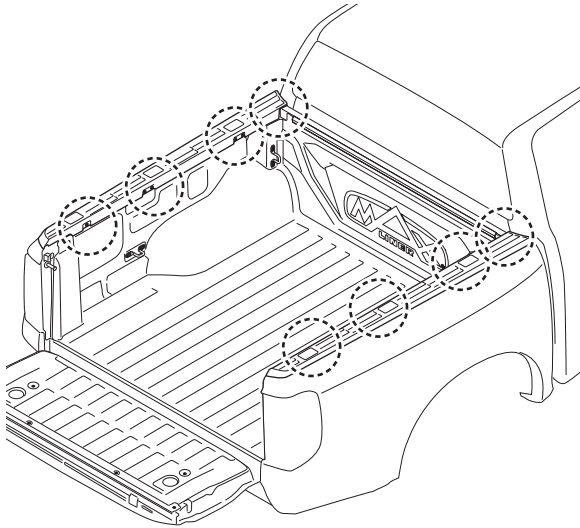

5

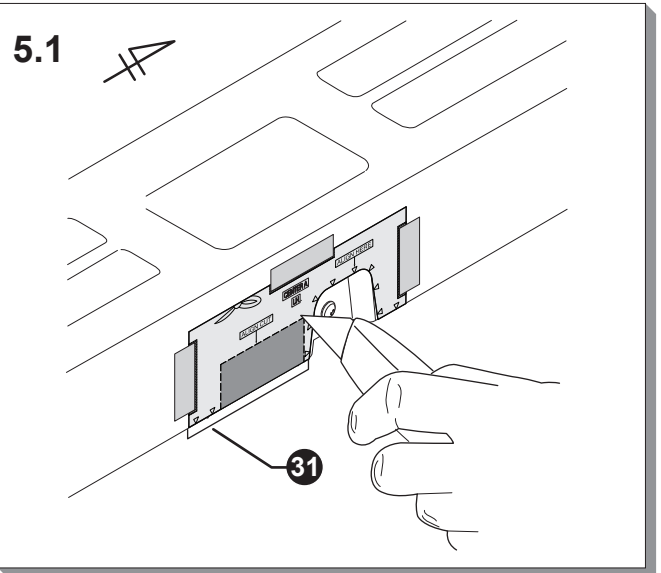
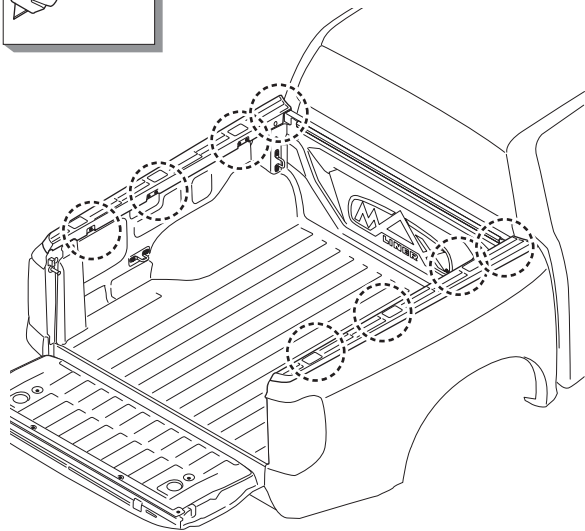
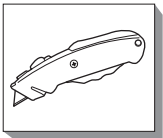

5.2

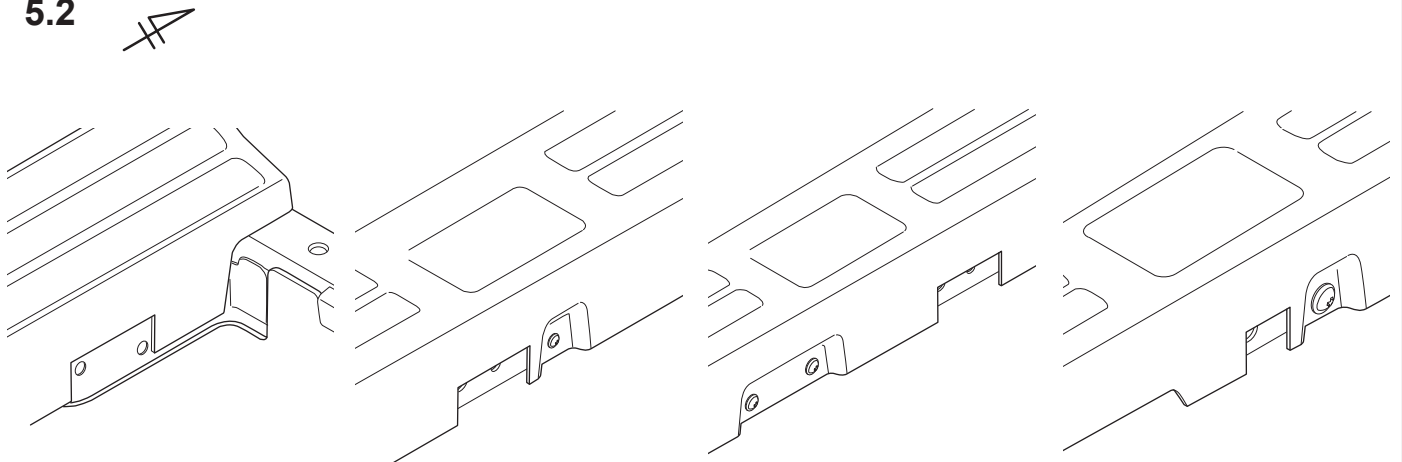

FRONT LH

CENTER A LH

CENTER B LH

REAR LH

Instruction procedure

6

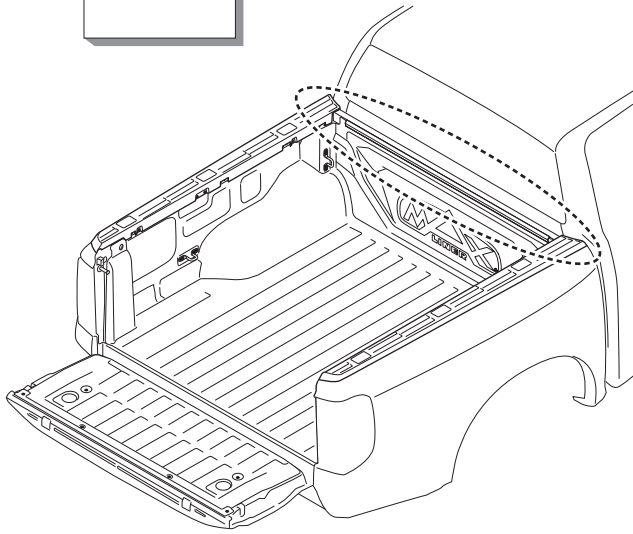
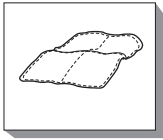

6.1

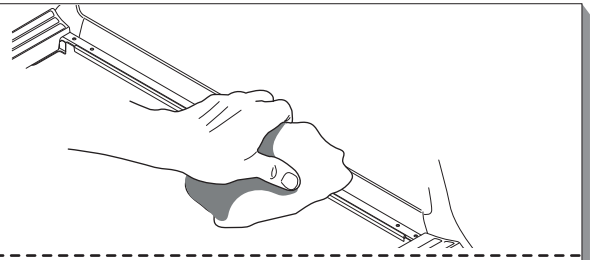

6.2

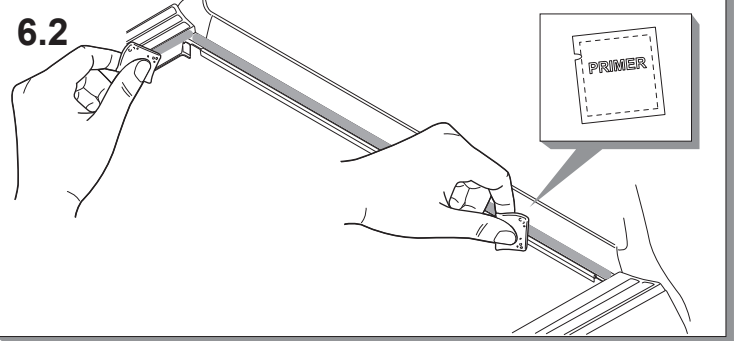

7

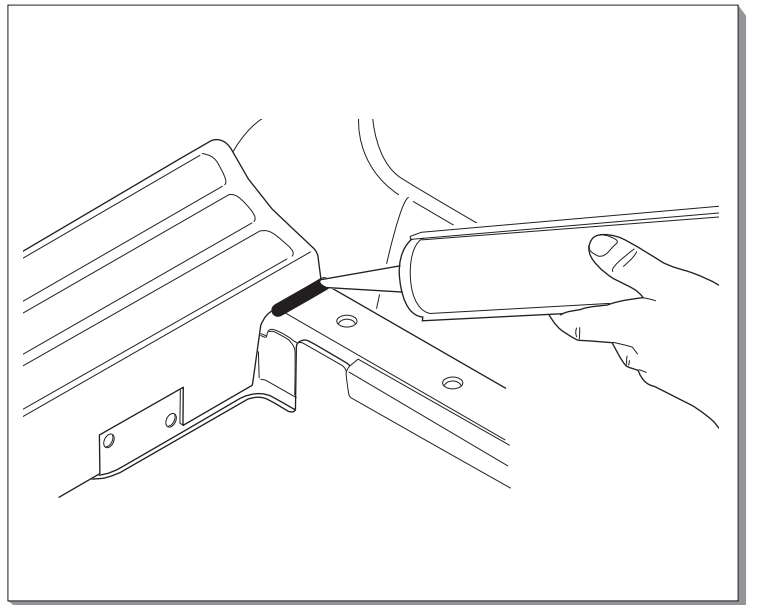
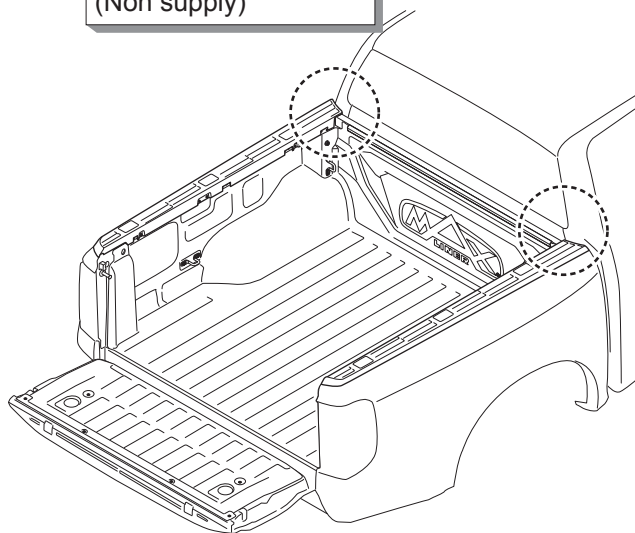
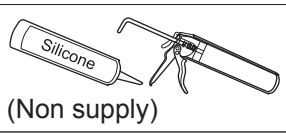

8

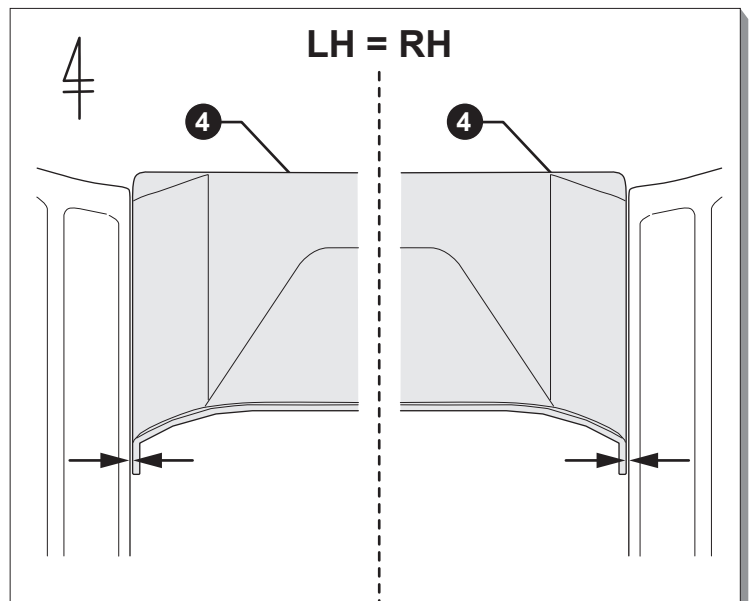
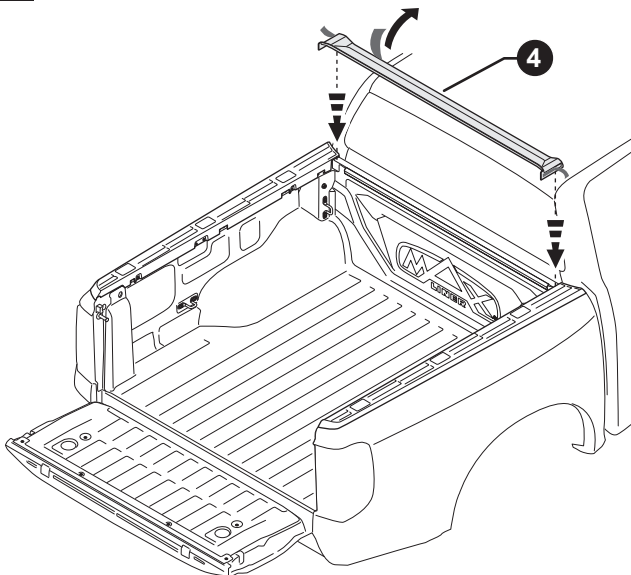

Instruction procedure

9

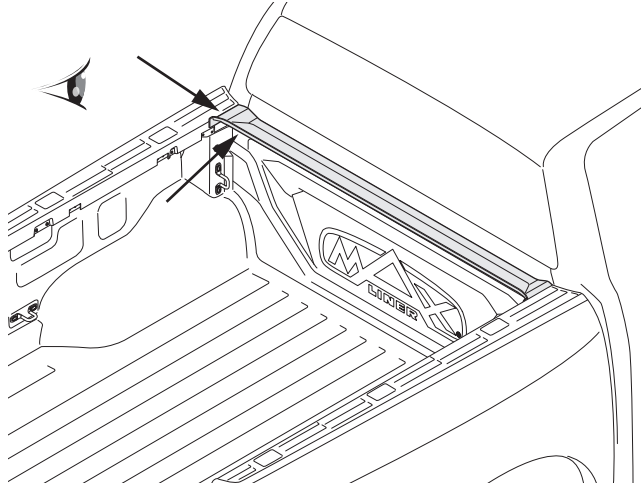
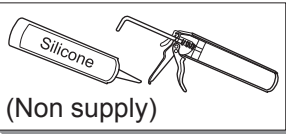

LH/RH

4

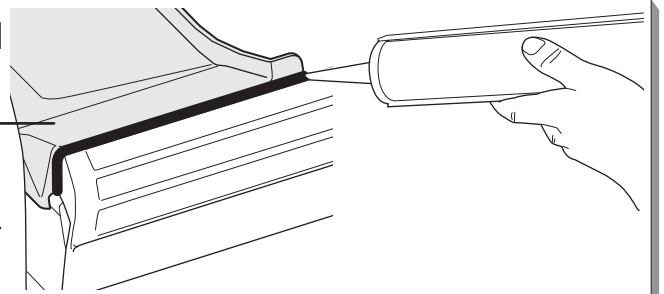

LH/RH



4

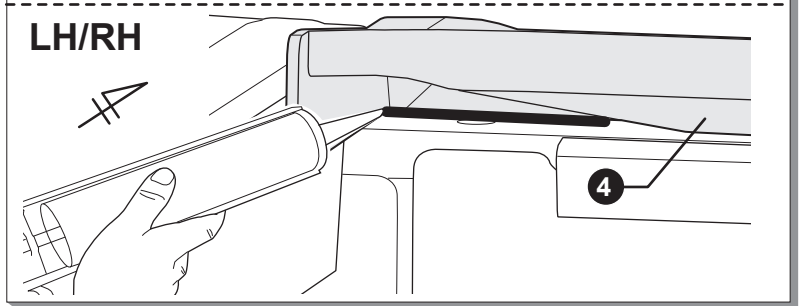

10 10.1
LH/RH

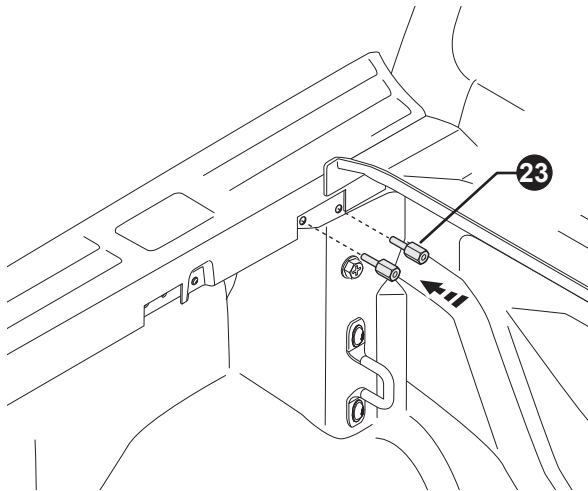
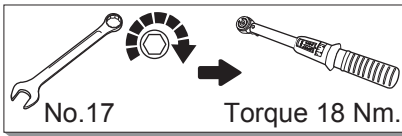

10.2
LH/RH

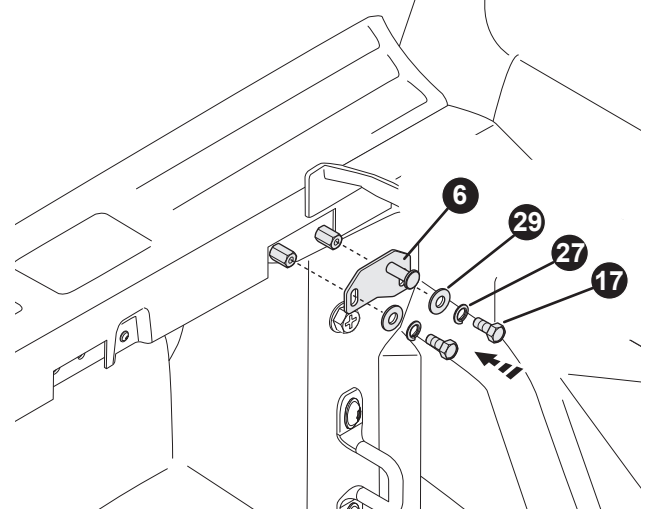
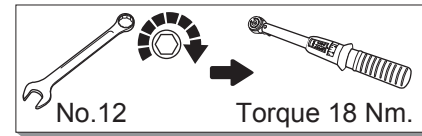

11 LH/RH

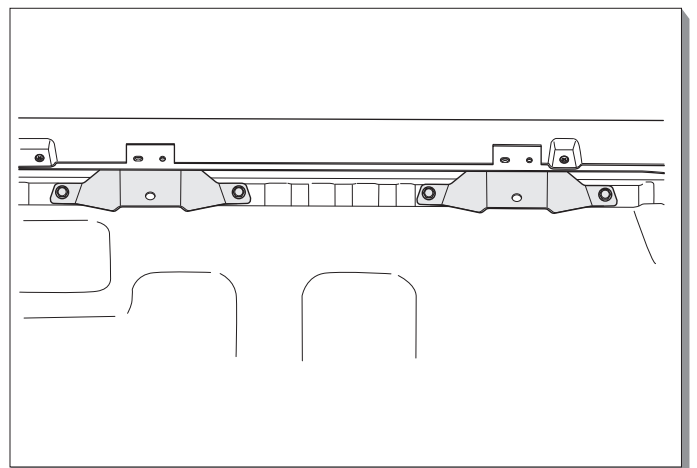
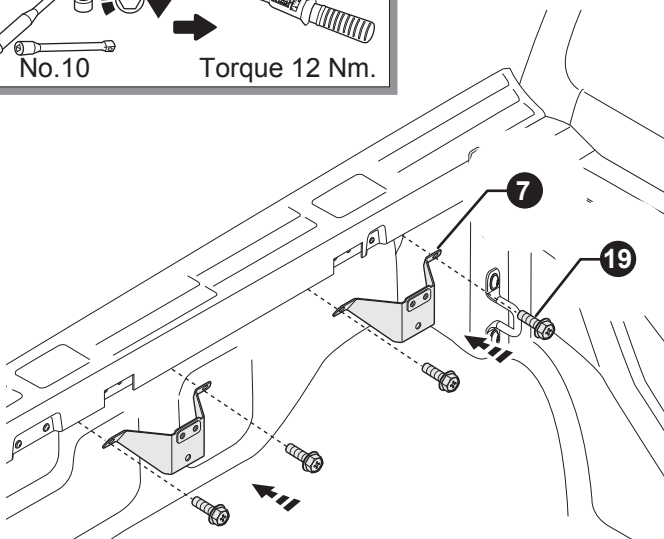
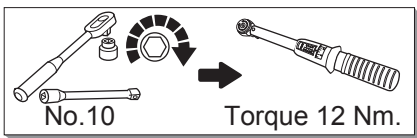

Instruction procedure

12 12.1 LH/RH

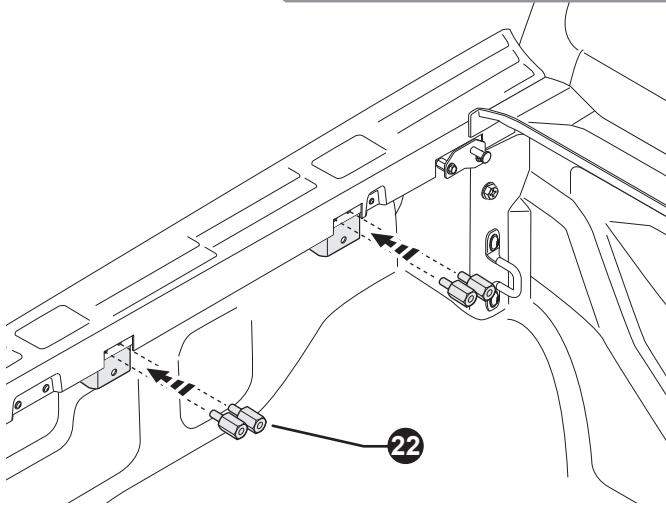
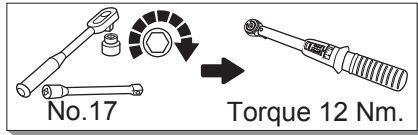

12.2 LH/RH

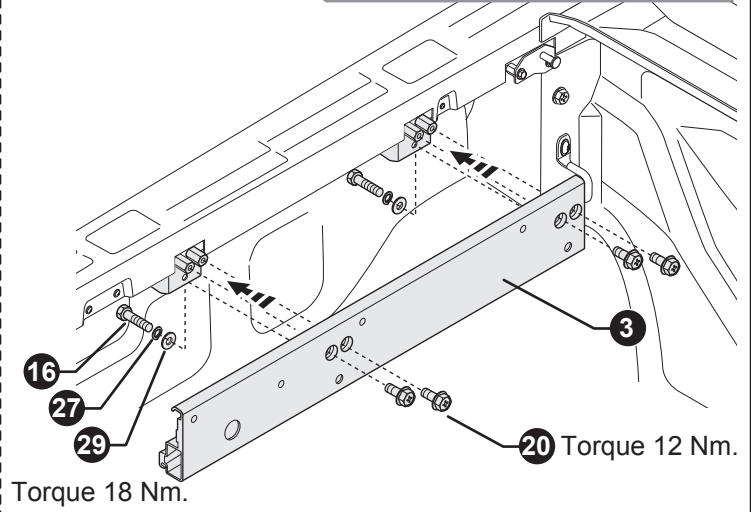
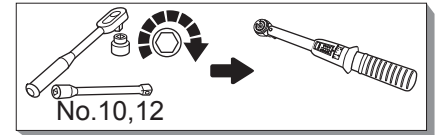

Section

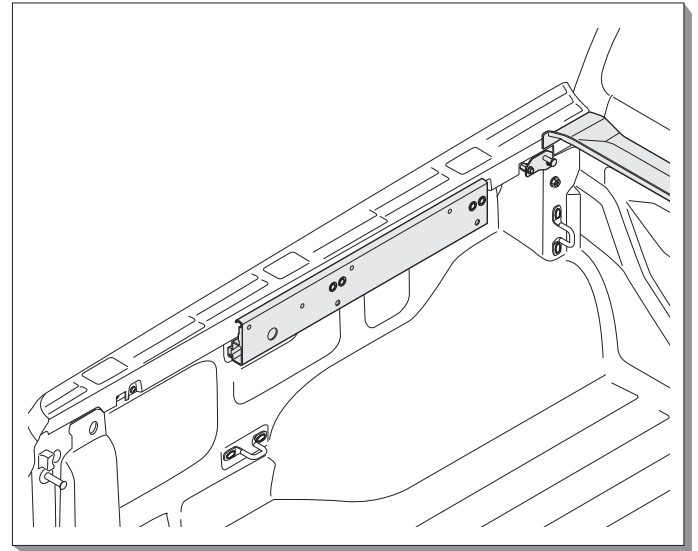
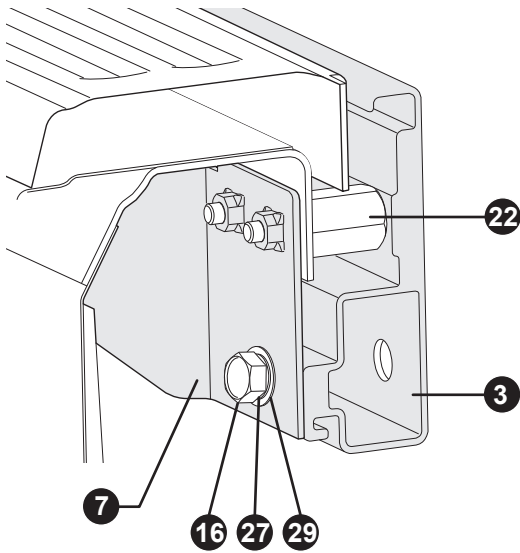

13

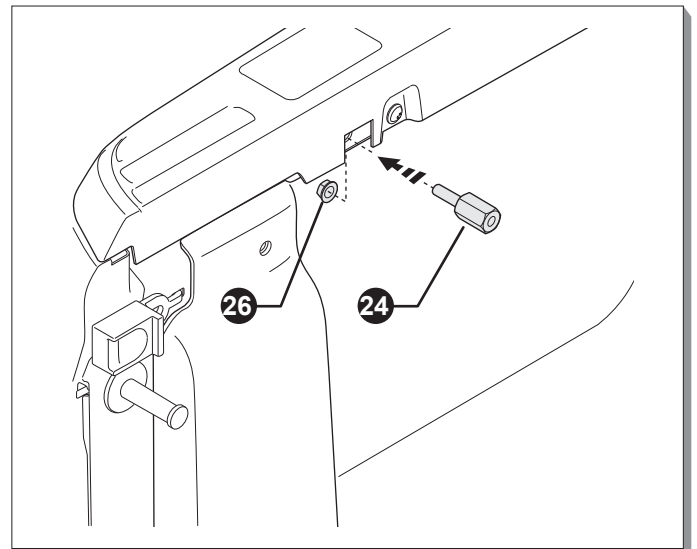
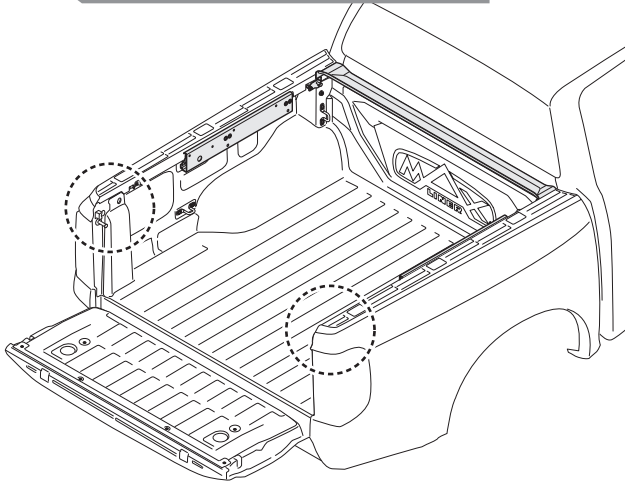
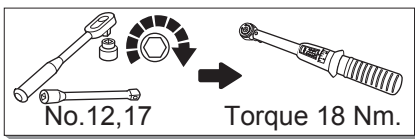

Instruction procedure

14 LH/RH

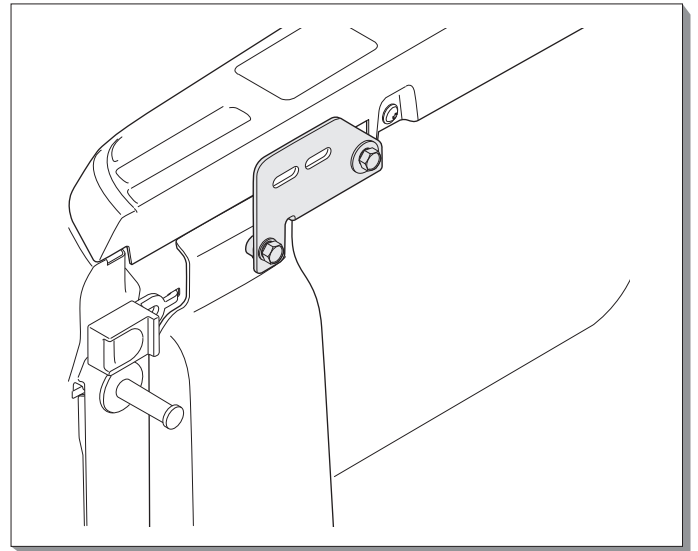
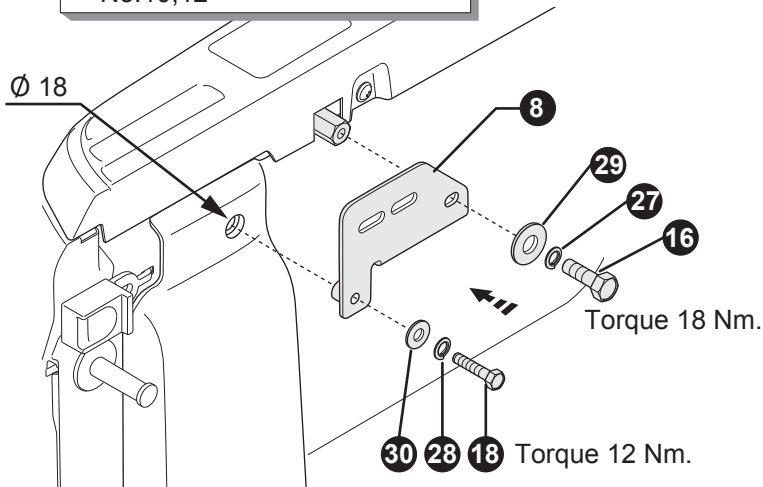
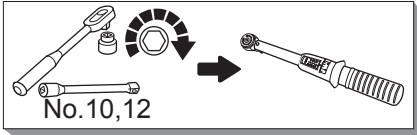

15 LH/RH

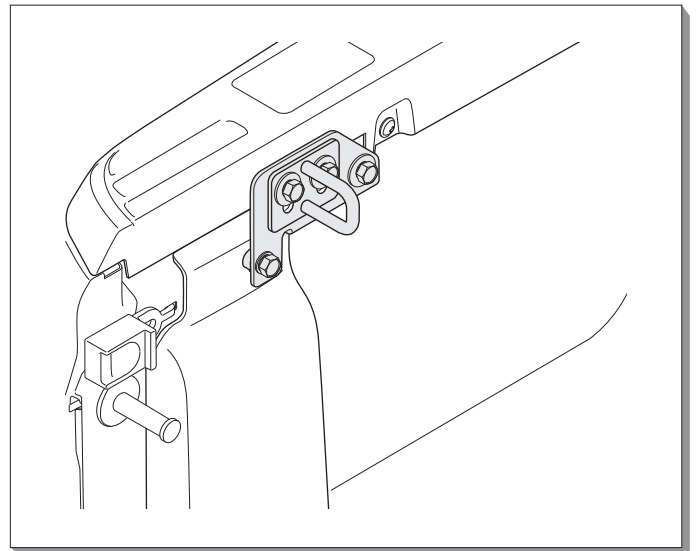
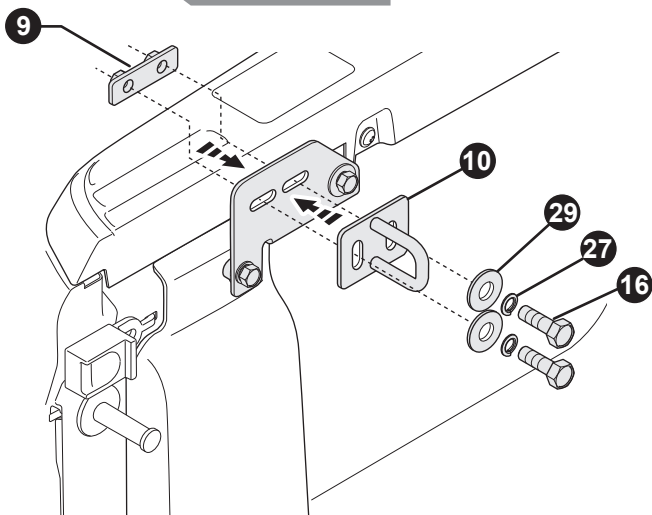
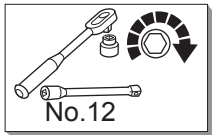

16 LH/RH

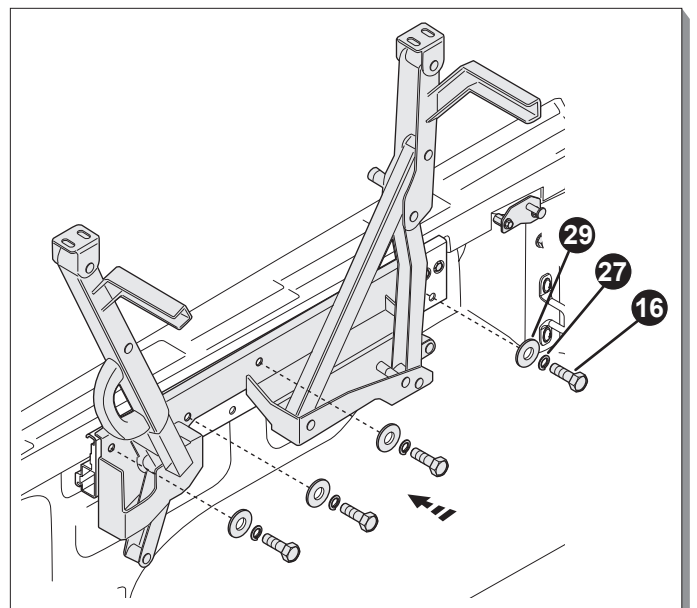
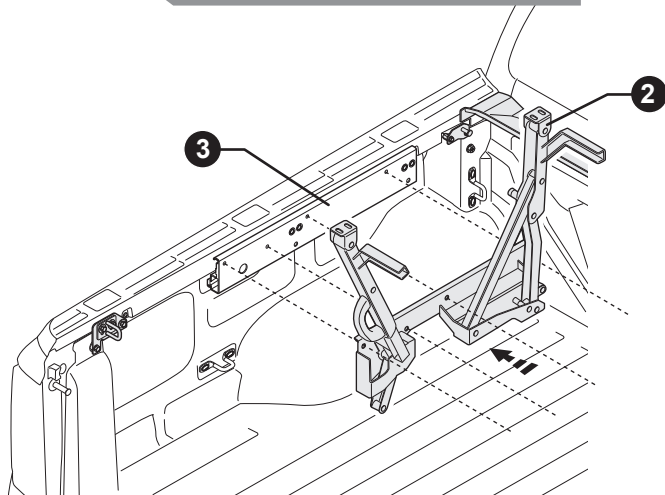
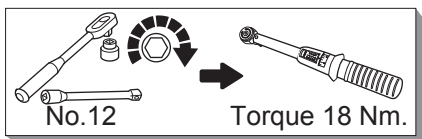

Instruction procedure

17 17.1
LH/RH

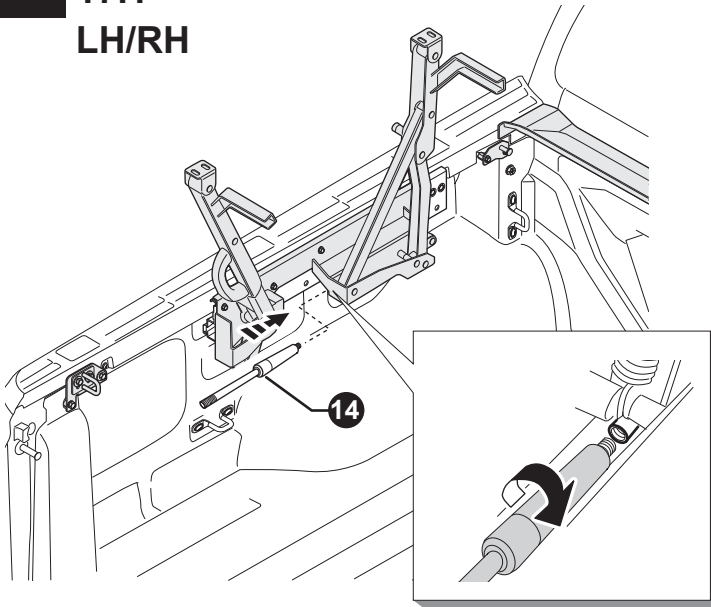

17.2
LH/RH

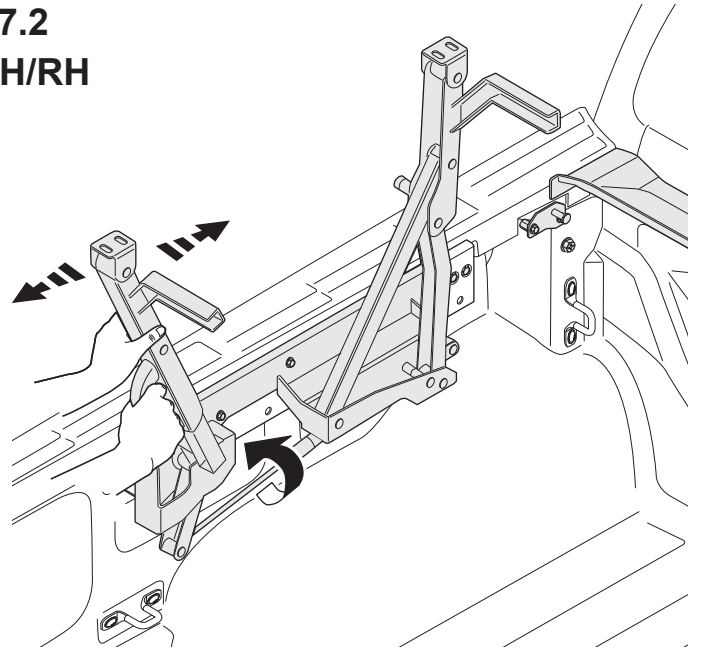

18

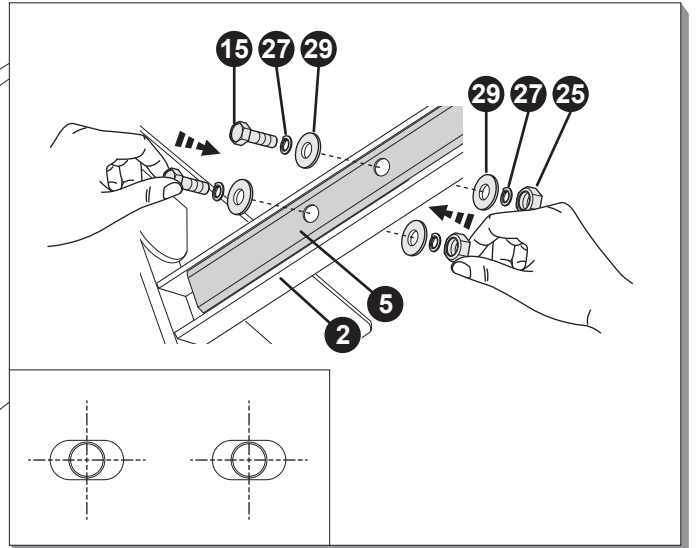
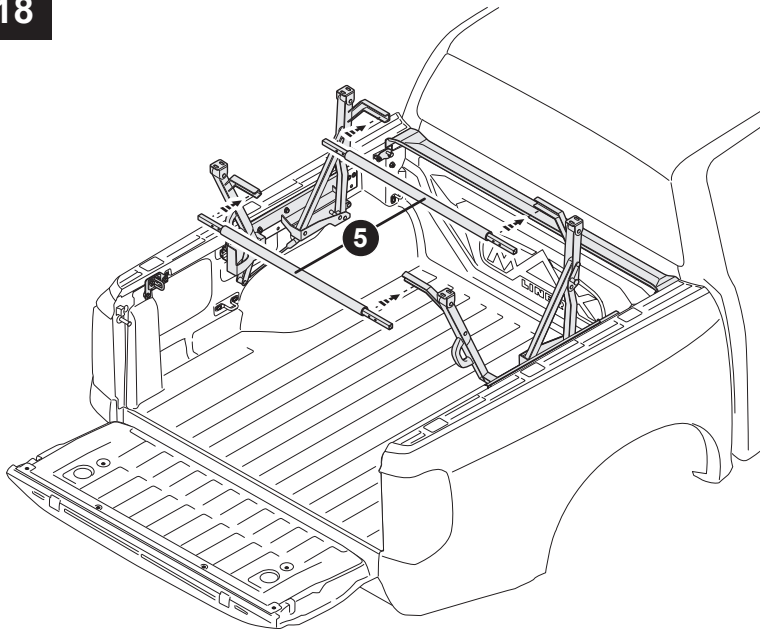

19

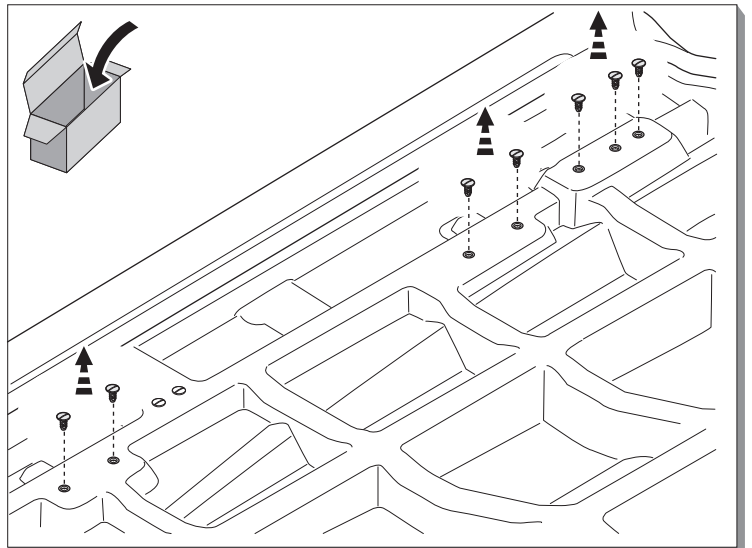
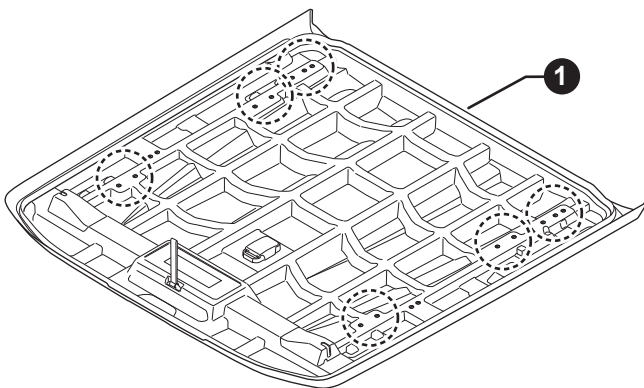
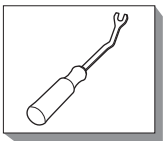

Instruction procedure

20

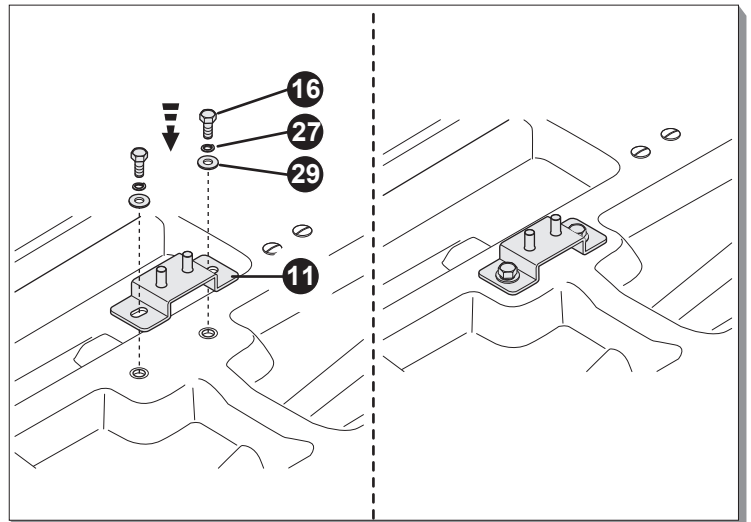
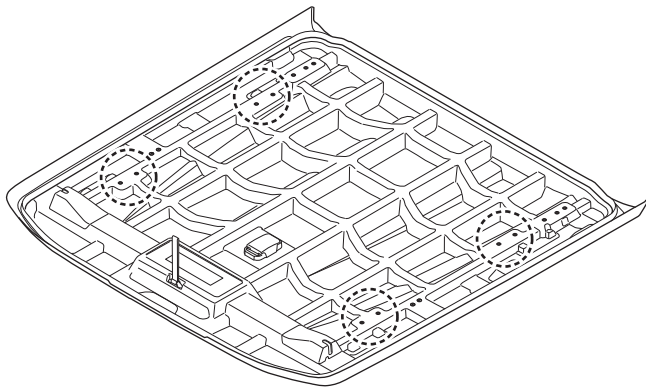
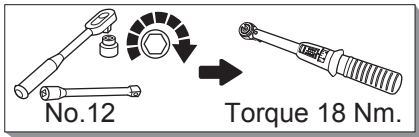

21

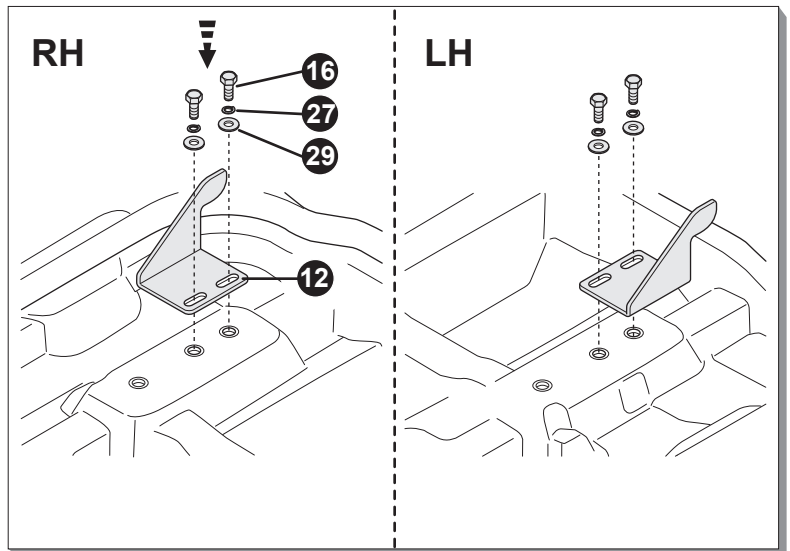
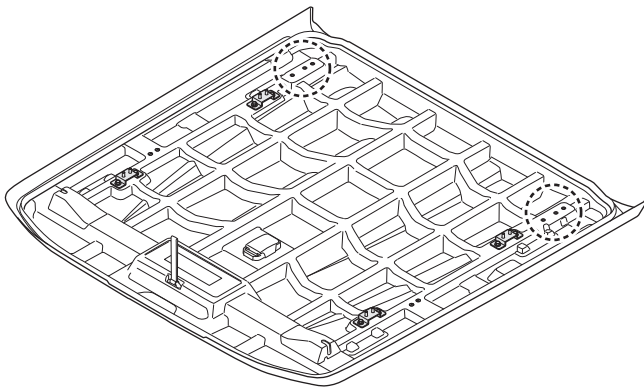
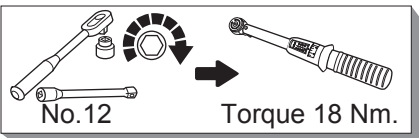

22

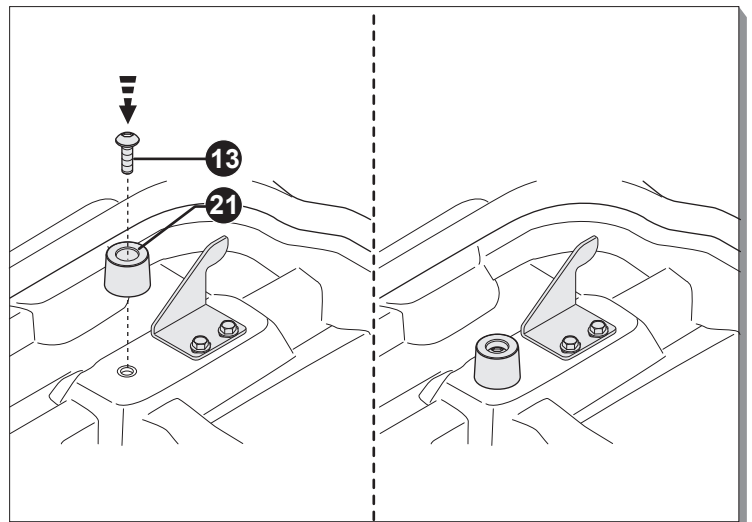
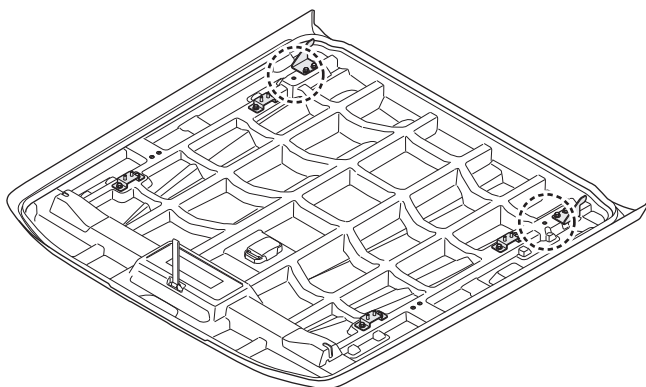
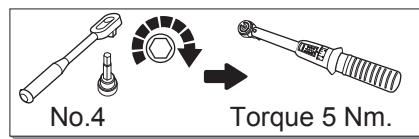

Instruction procedure

23

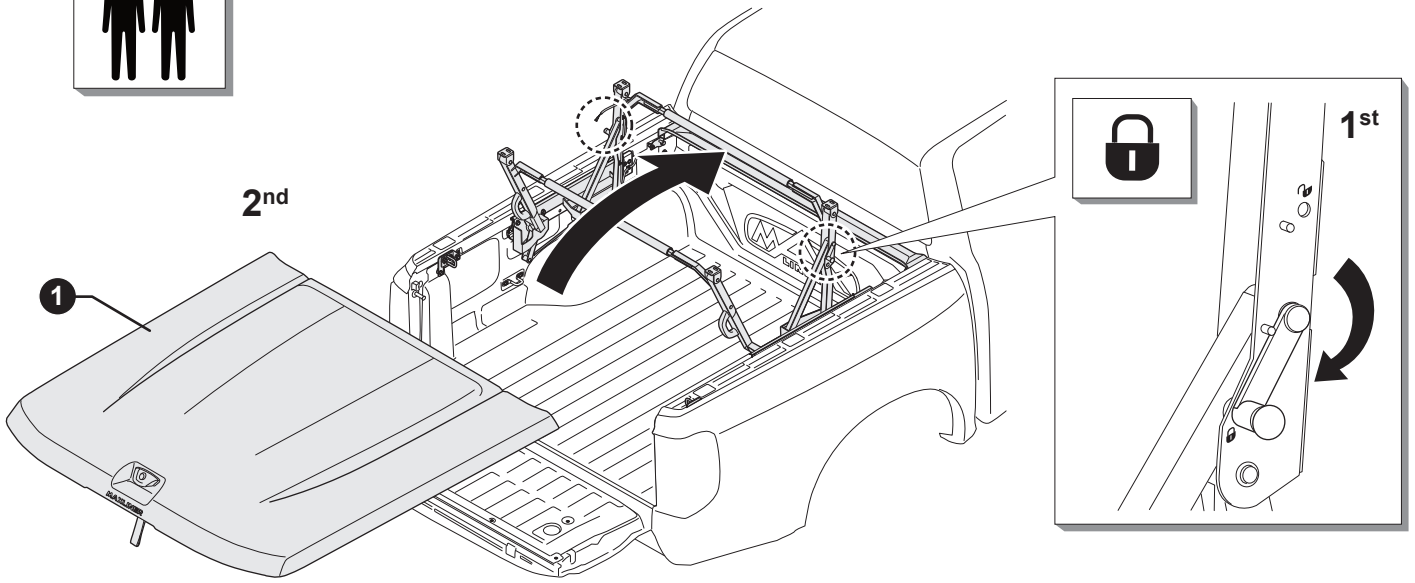
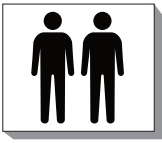

24

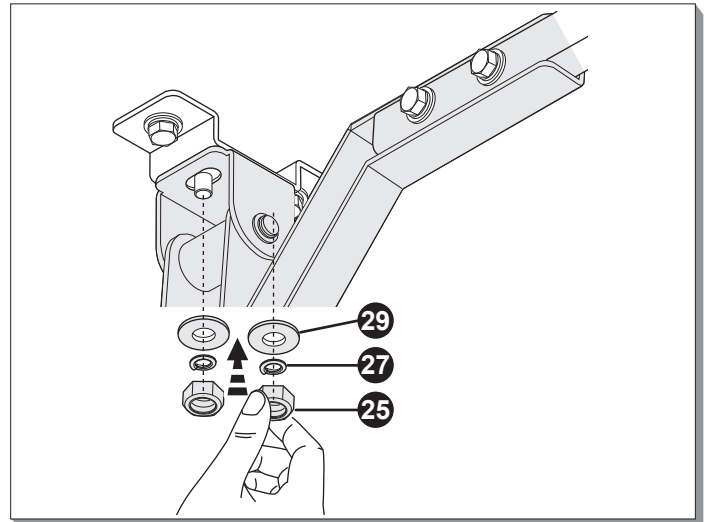
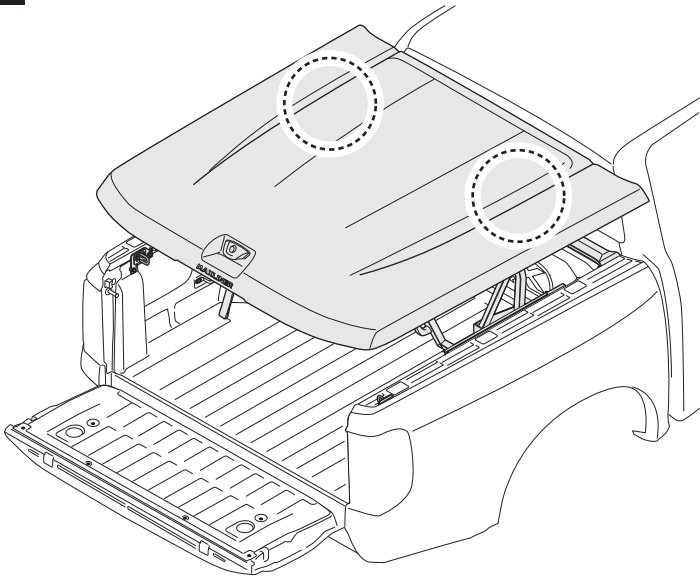

25

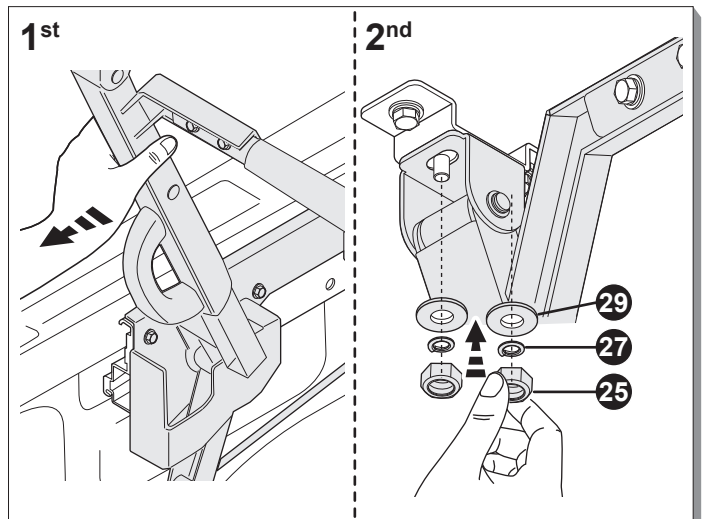
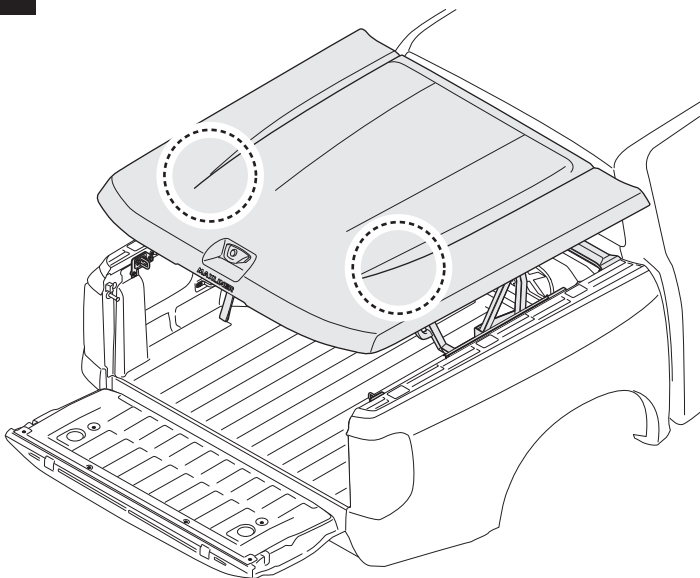

Instruction procedure

26

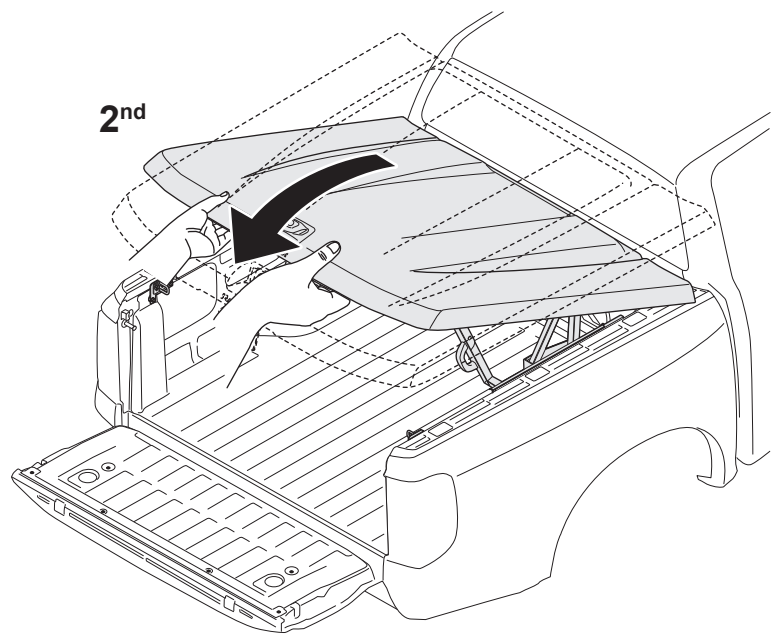
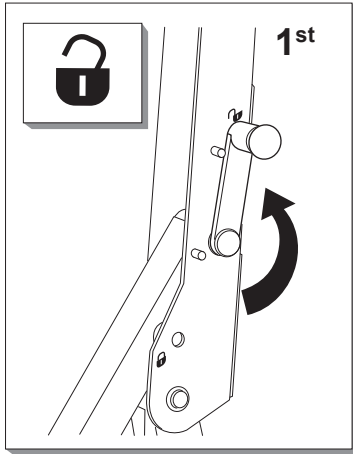

27

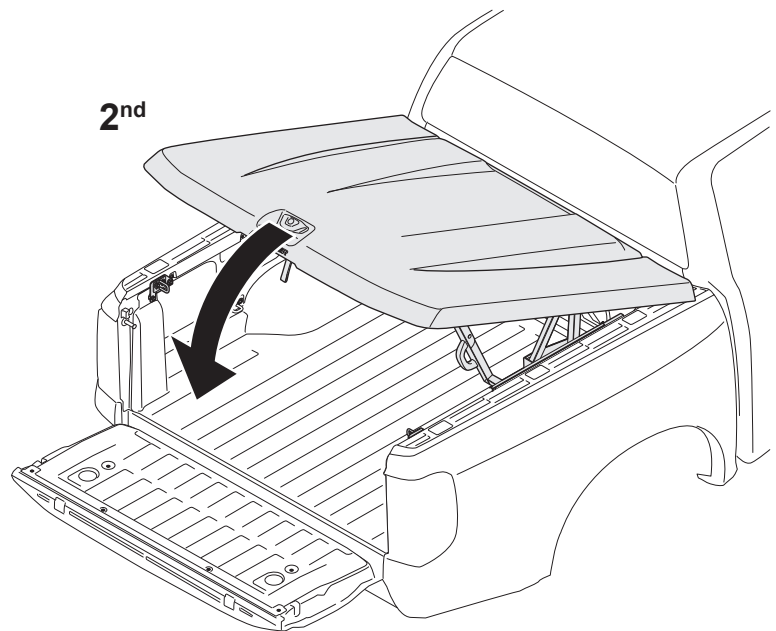
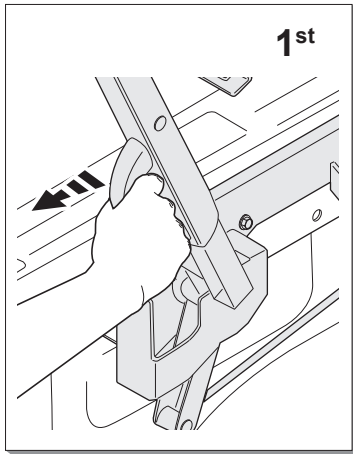

28

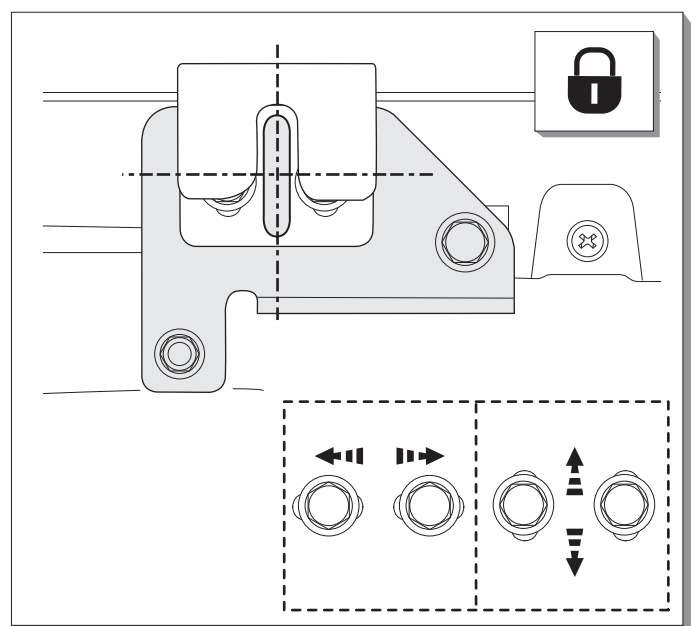
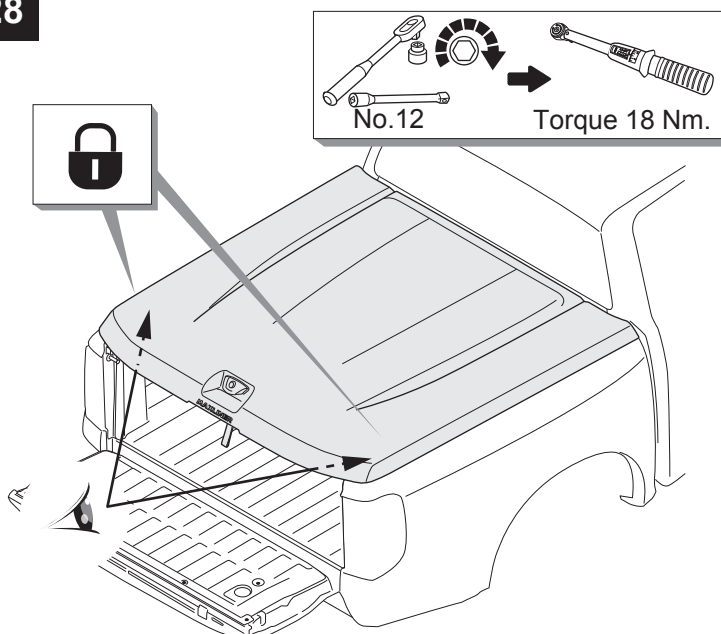

Instruction procedure

29

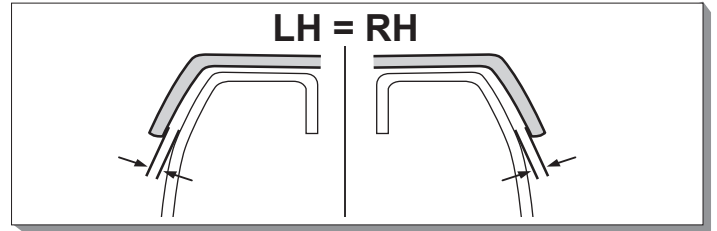
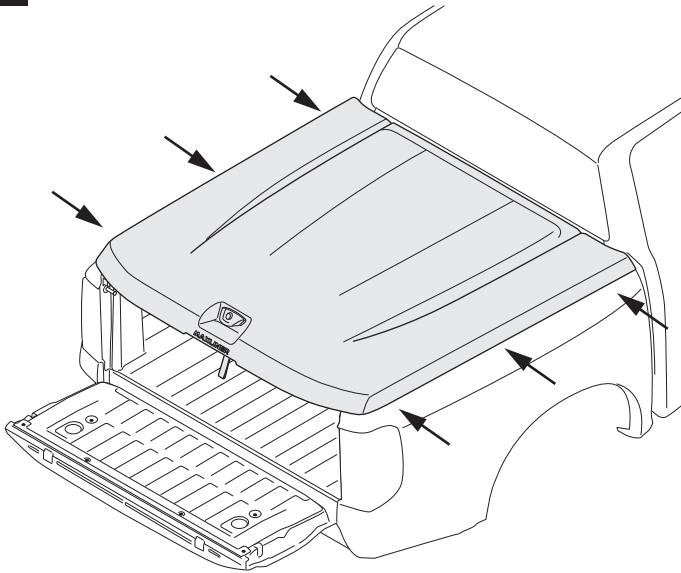

30

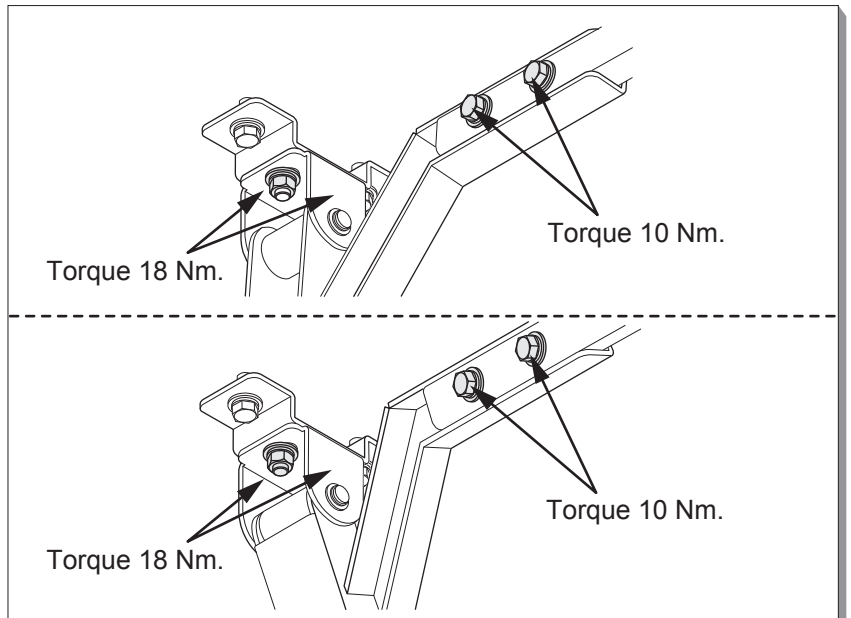
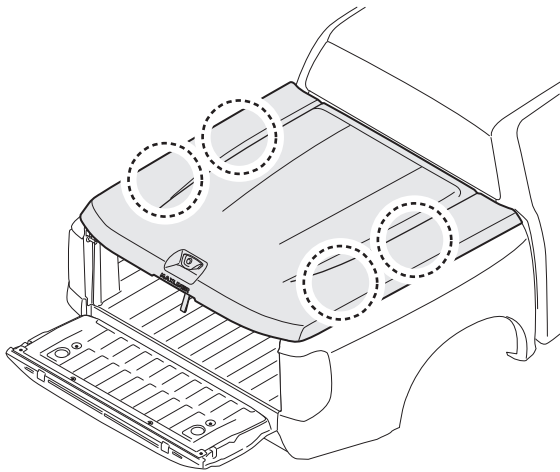
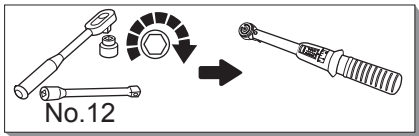

31

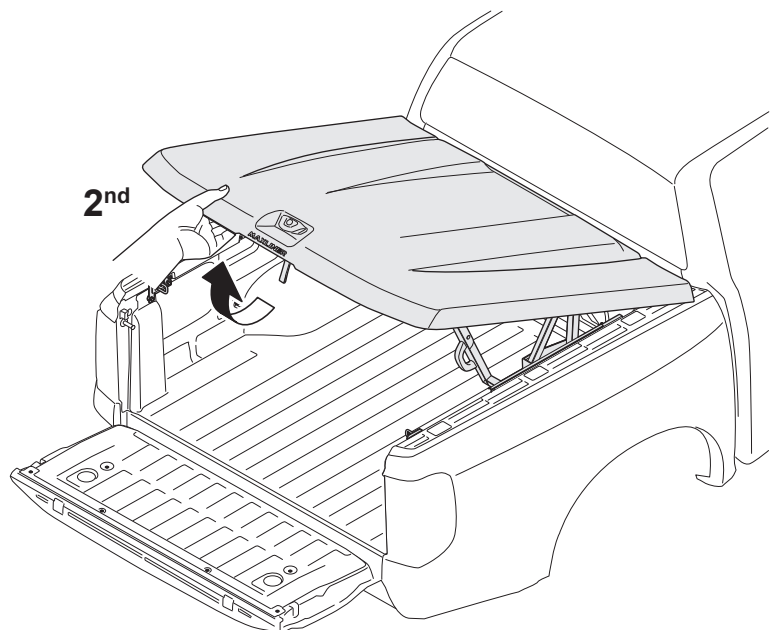
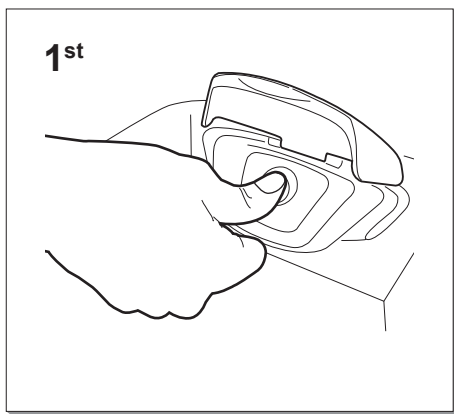

Instruction procedure

32

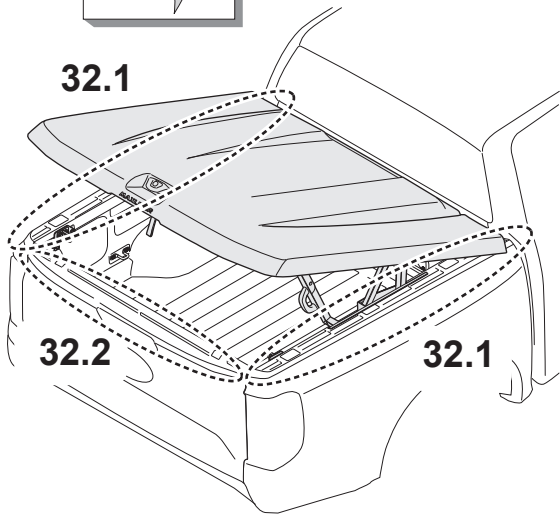
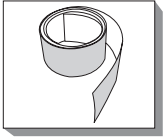

32.1

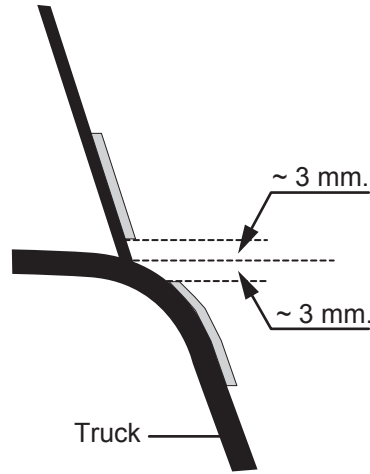

32.2

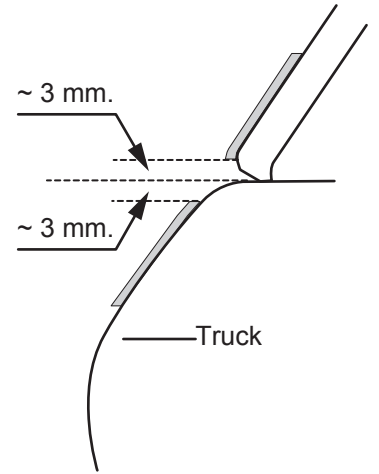

33

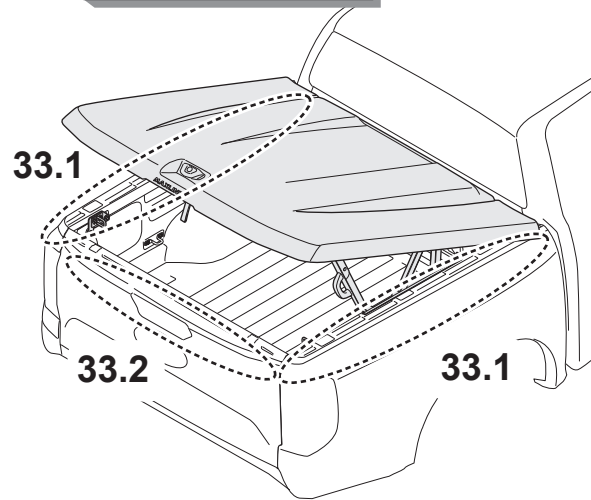
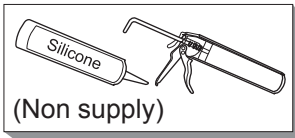

33.1

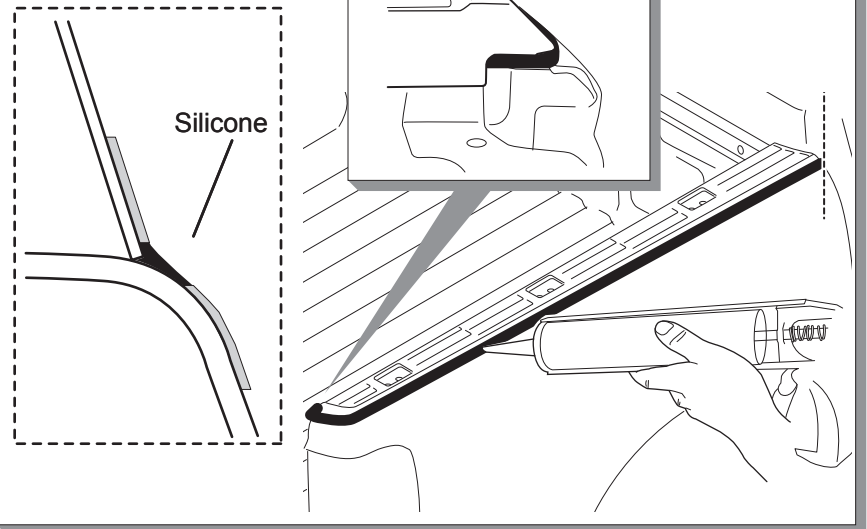

33.2

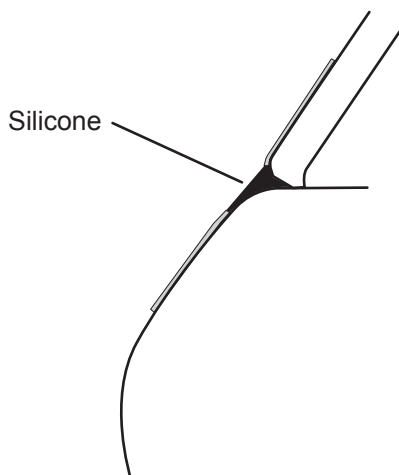

33.3

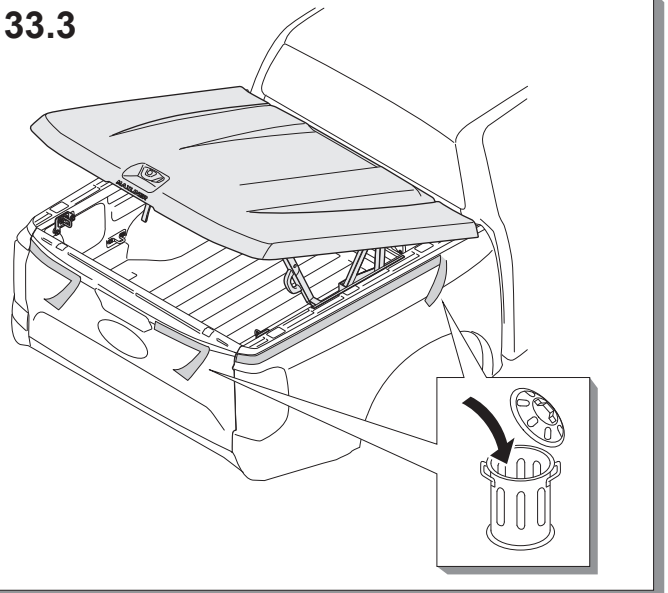

※ Open & Close

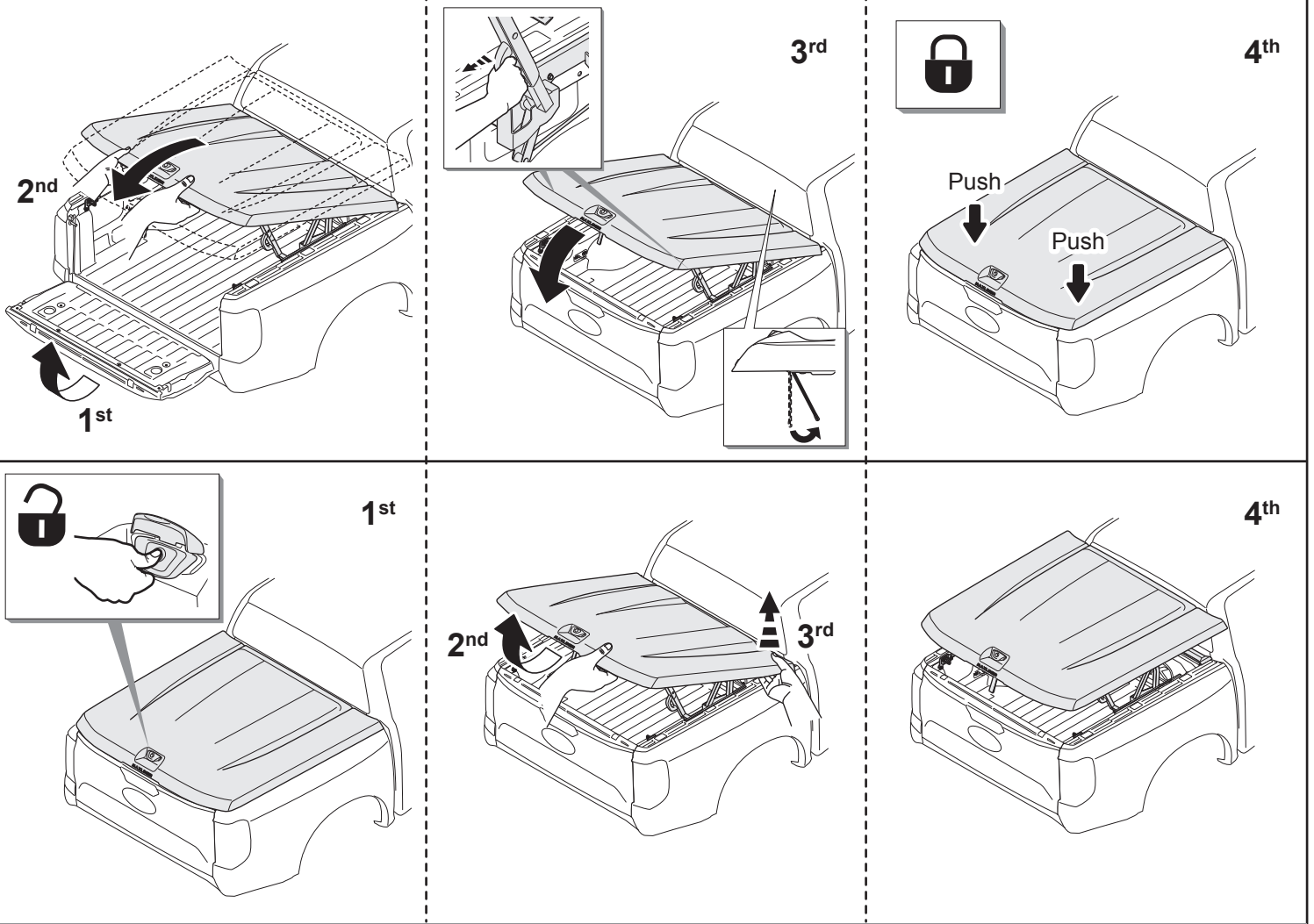

※ Interior light on-off

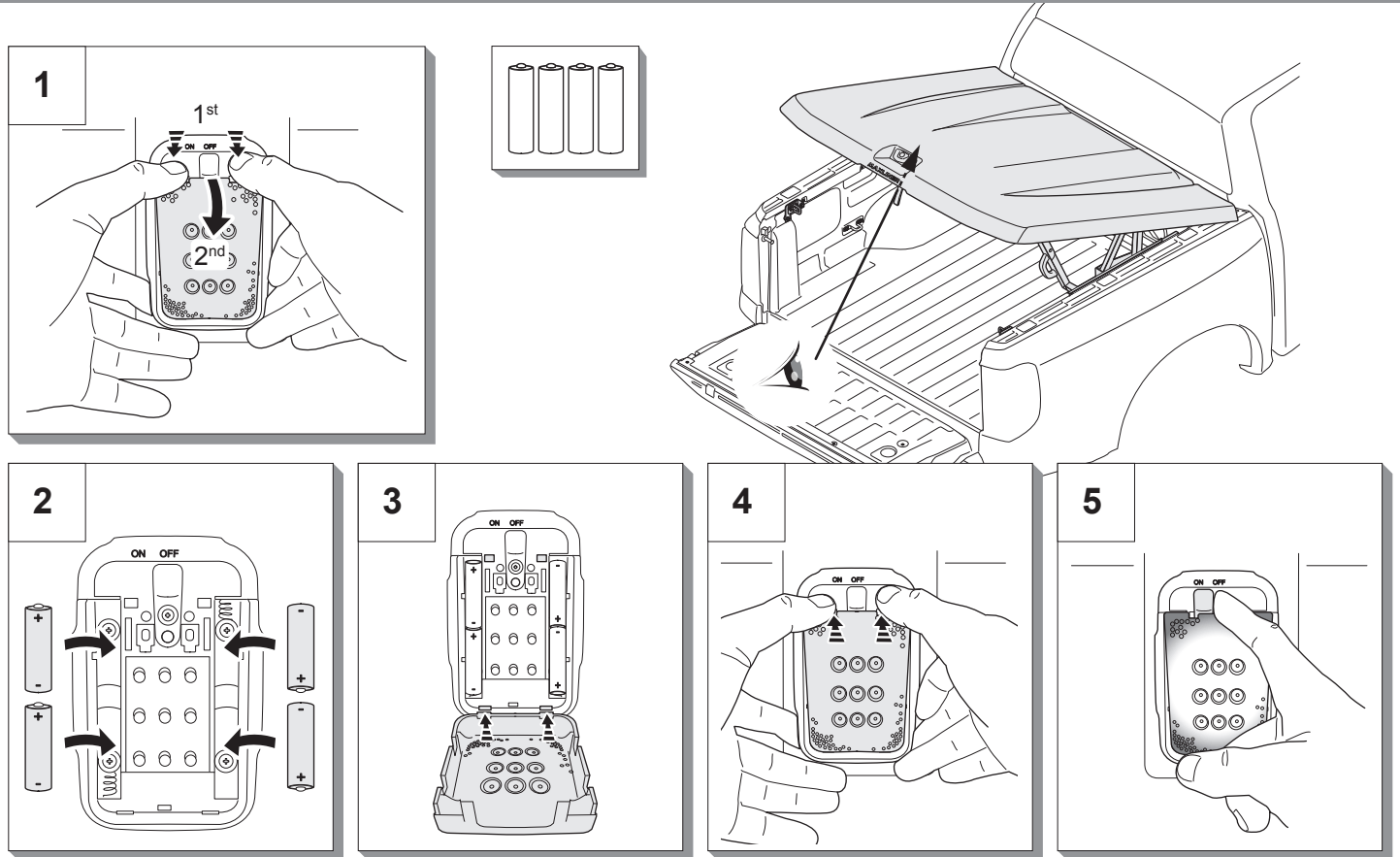

※ Adjust double lock

Case: 1

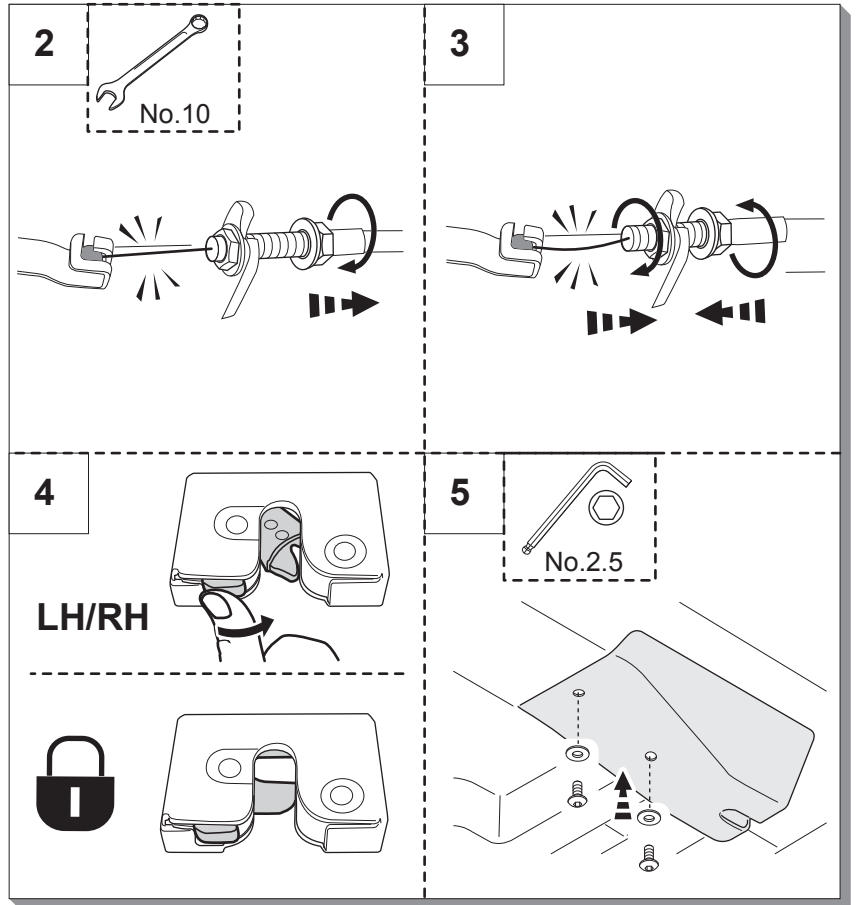
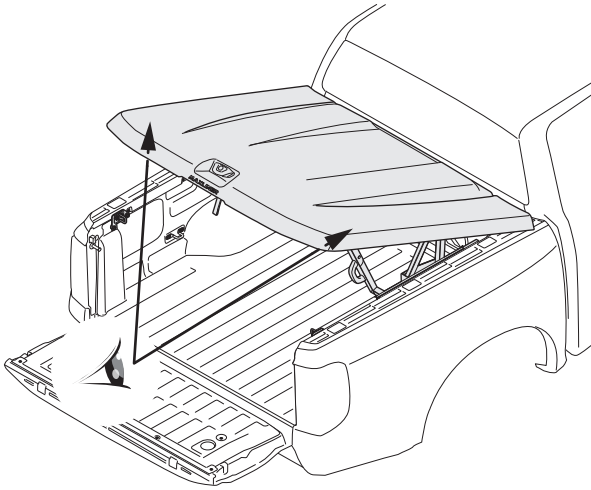
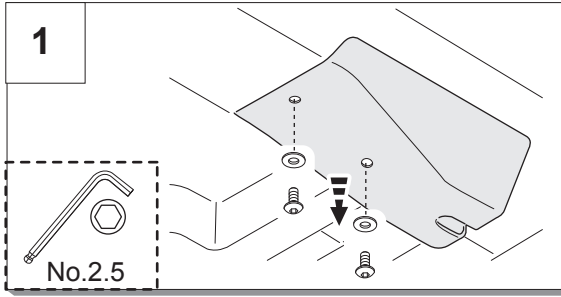

Case: 2

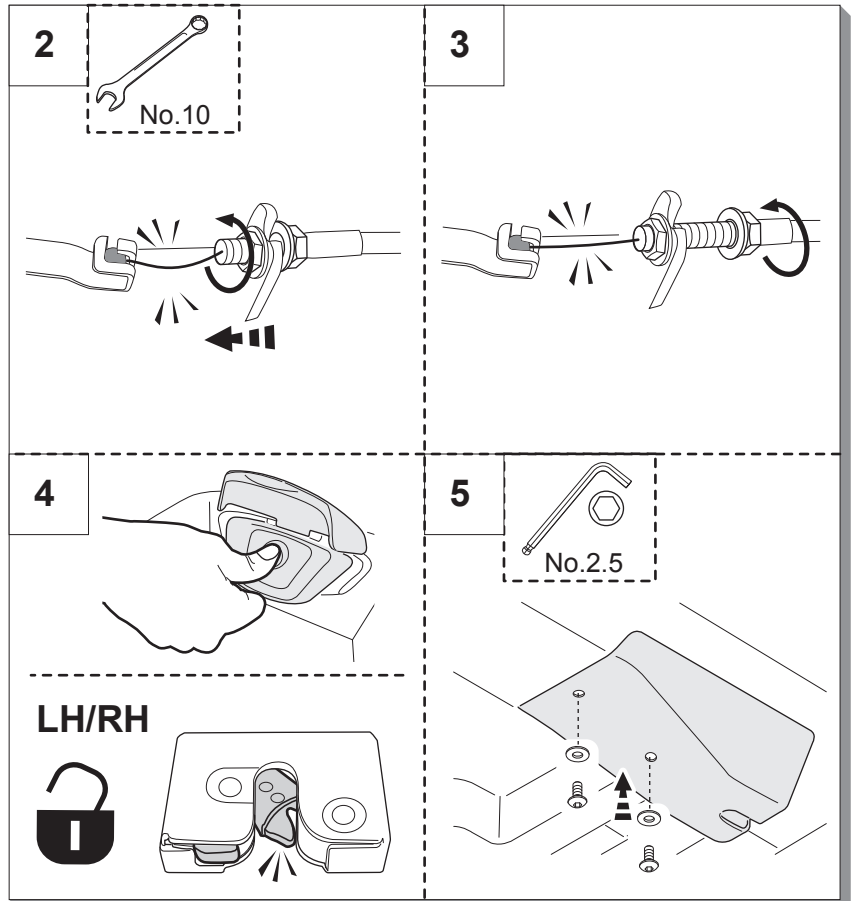
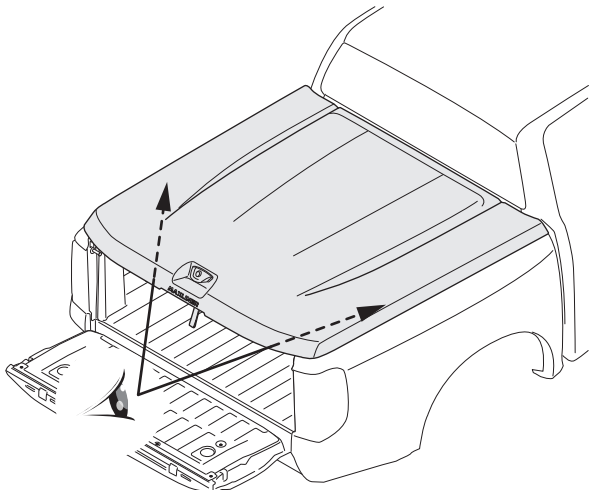
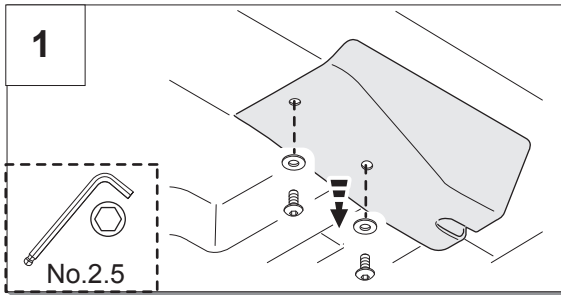

※ Painting body

1

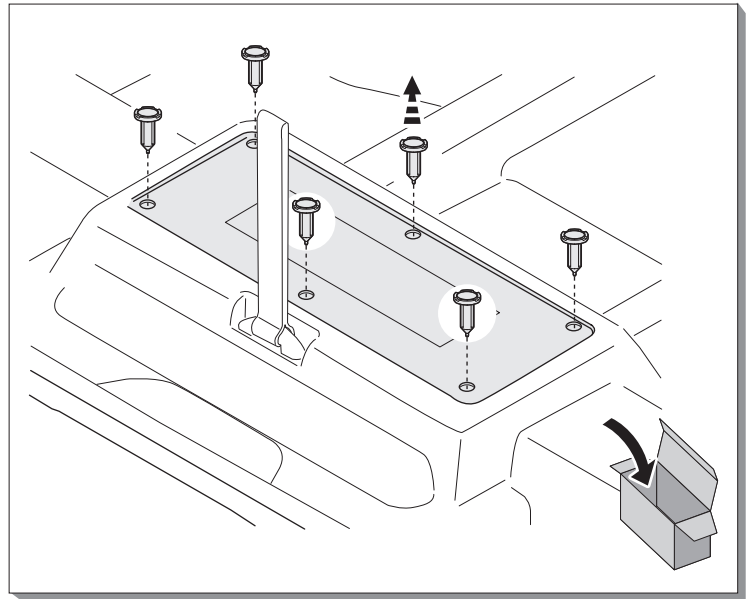
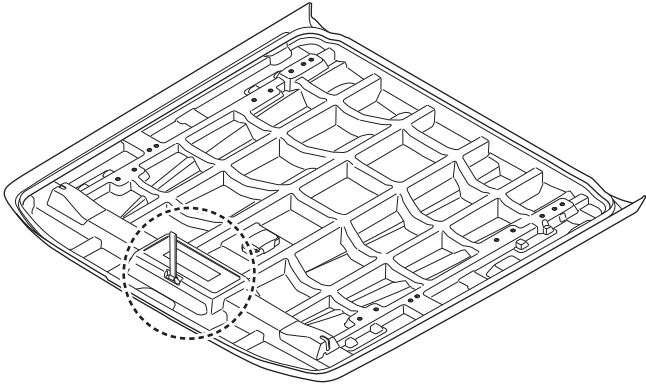
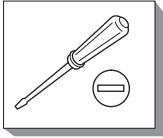

2

2.1

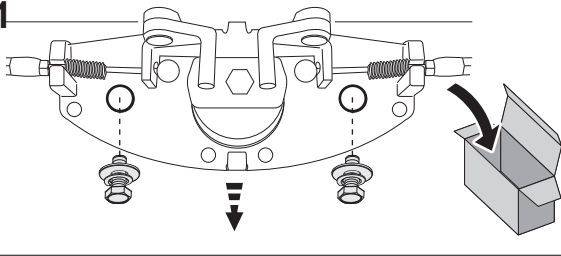

2.2

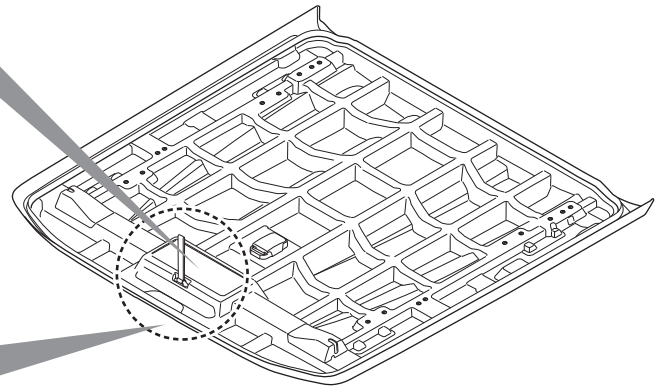
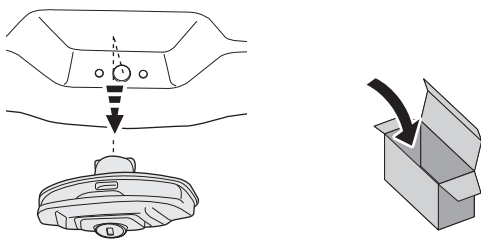

3

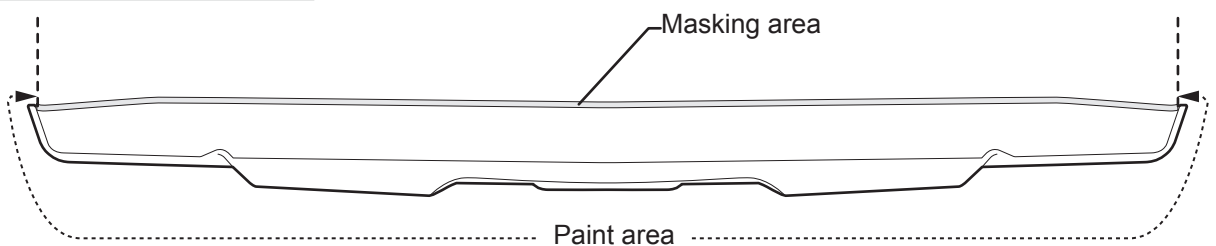
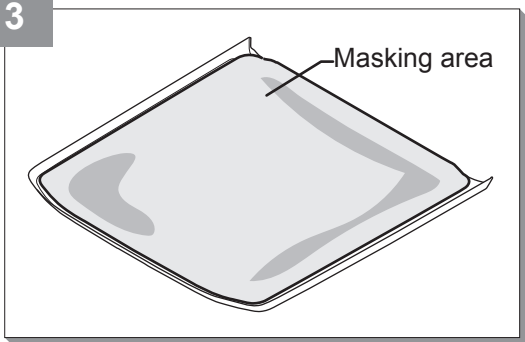

※ Painting body

4

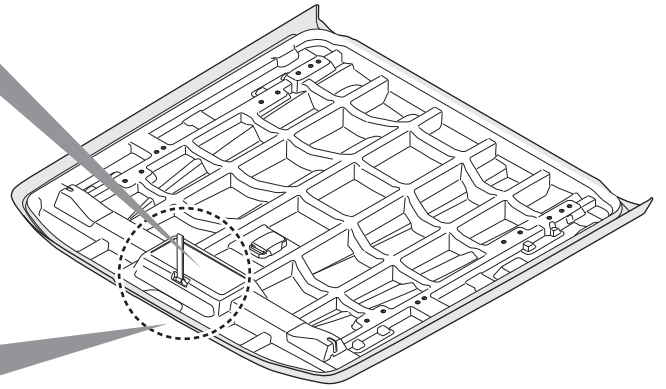
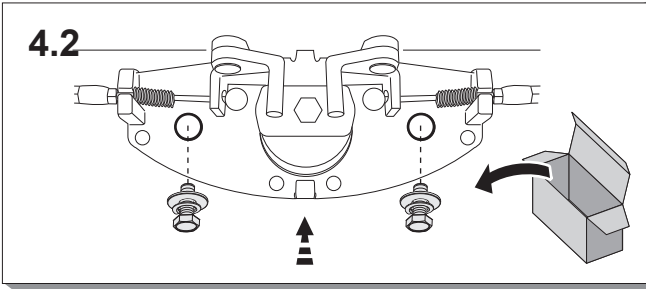
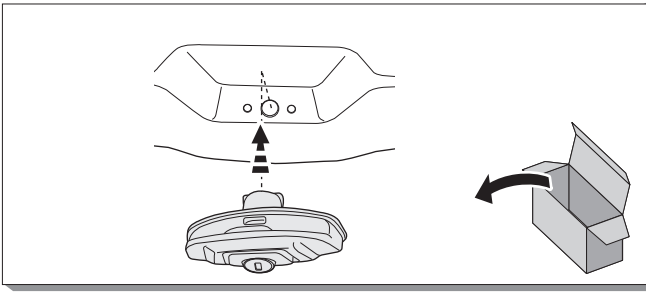

5

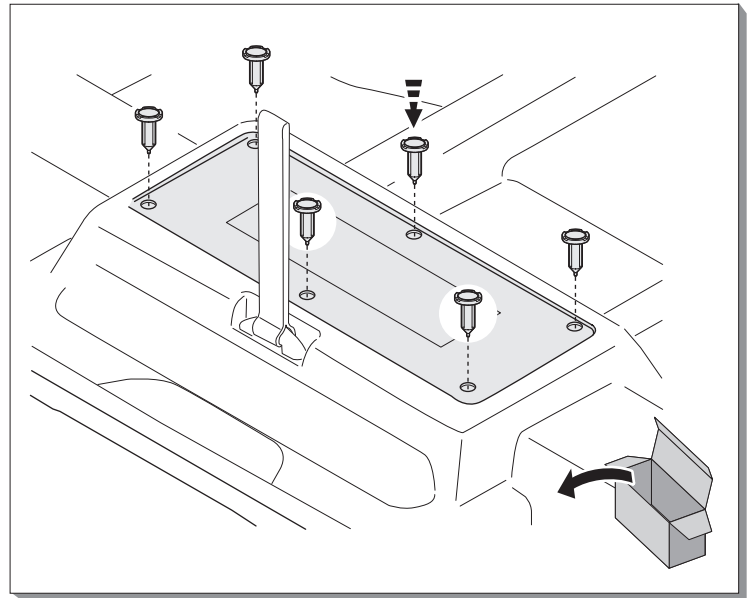
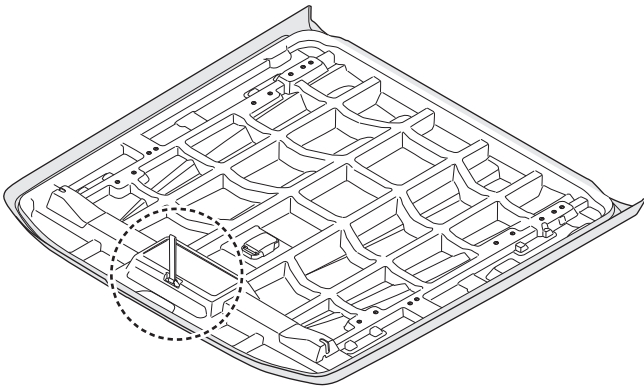

6

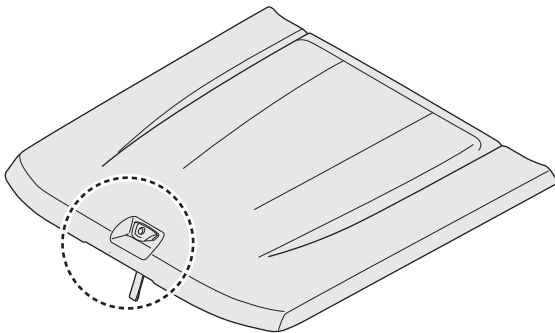

1st

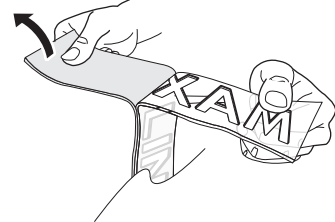

2nd

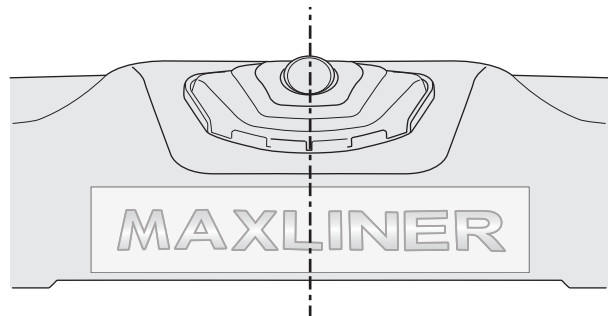

※ Painting body

7

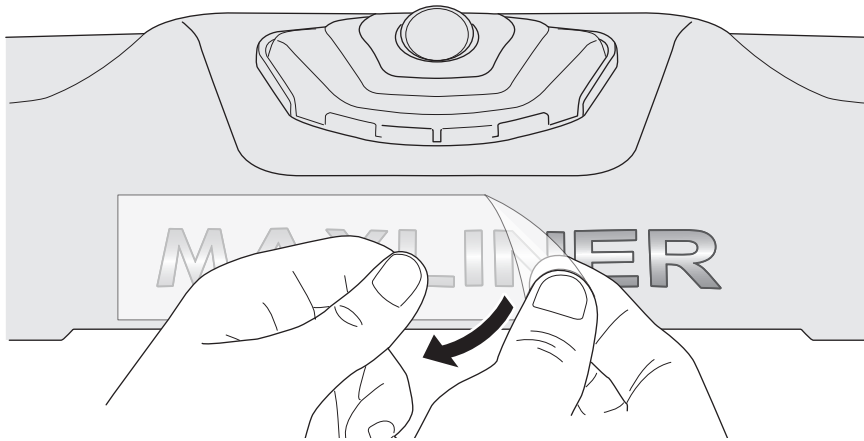

8

